

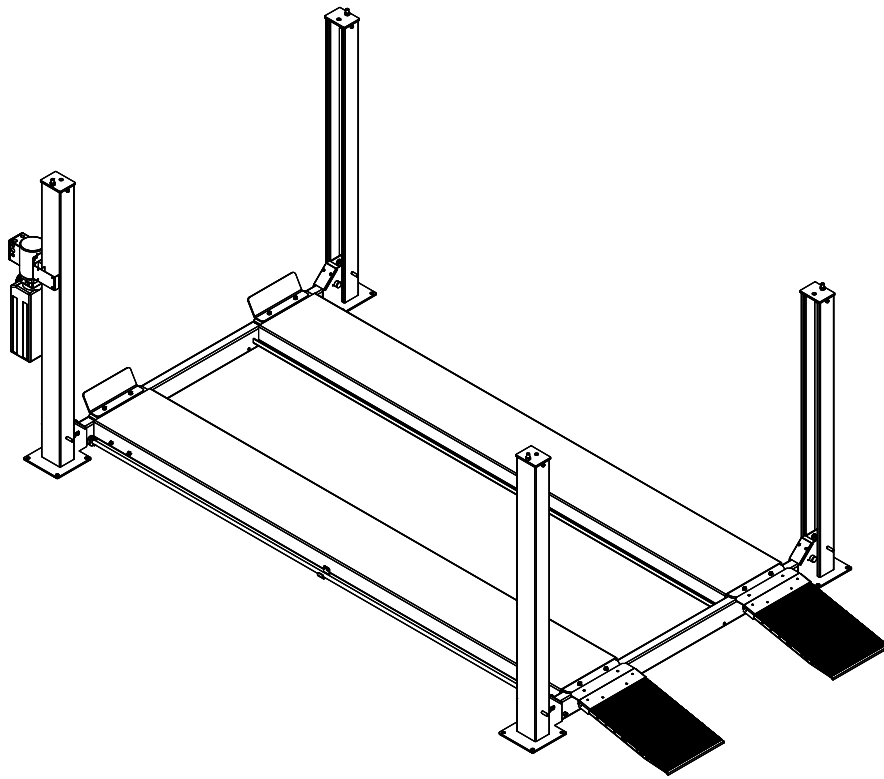

Installation, Operation & Maintenance Manual

Four Post

Surface Mounted Lift



Models Q4P09H, Q4P09X & Q4P09W
(9,000 lb. Capacity)

2311 South Park Rd Louisville, Kentucky 40219

Email: sales@challengerlifts.com Web site: www.challengerlifts.com

Office 877-771-5438/ 502-583-5438 Fax 502-583-5488

IMPORTANT: READ THIS MANUAL COMPLETELY BEFORE
INSTALLING or OPERATING LIFT

GENERAL SPECIFICATIONS

SPECIFICATIONS	Q4P09H	Q4P09X	Q4P09W
A Length Overall	209½" [17'-5½"]	233½" [19'-5½"]	233 ½" [19'-5½"]
B Width Overall	112¼"	112¼"	127¼"
C Inside Columns	95"	95"	110"
D Between Columns	160½" [13'-4½"]	184¾" [15'-4¾"]	184¾" [15'-4¾"]
E Height of Columns	84½"	96½"	96½"
F Height of Runways, Floor to Runway Top	7"min to 75-5/8" max	7"min to 87-7/8" max	7"min to 87-7/8" max
G Width of Runways	20"	20	20
H Width Between Runways	38"	38	38
I Rise Height of Runway Top at Top Lock Position. (allow 2-3/8" of clearance above top vehicle for lock release)	73¼"	85½"	85½"
Clear Height Underneath Runway (top lock position)	67 ¾"	80"	80"
J Length, Base Plate to Base Plate	179-1/4"	203-1/2"	203-1/2"
K Maximum Wheelbase *	155"	179"	179"
Lifting Capacity	9,000 lbs.		
Motor: HP/Voltage, single phase std	1HP/115v or 2HP/220v		
Speed of Rise (approximate)	120 Seconds/115v or 60 seconds/220v		
Runway Length (not including mounting flange)	164"	188"	188"

* Wheelbase is based on a tire diameter of 30"

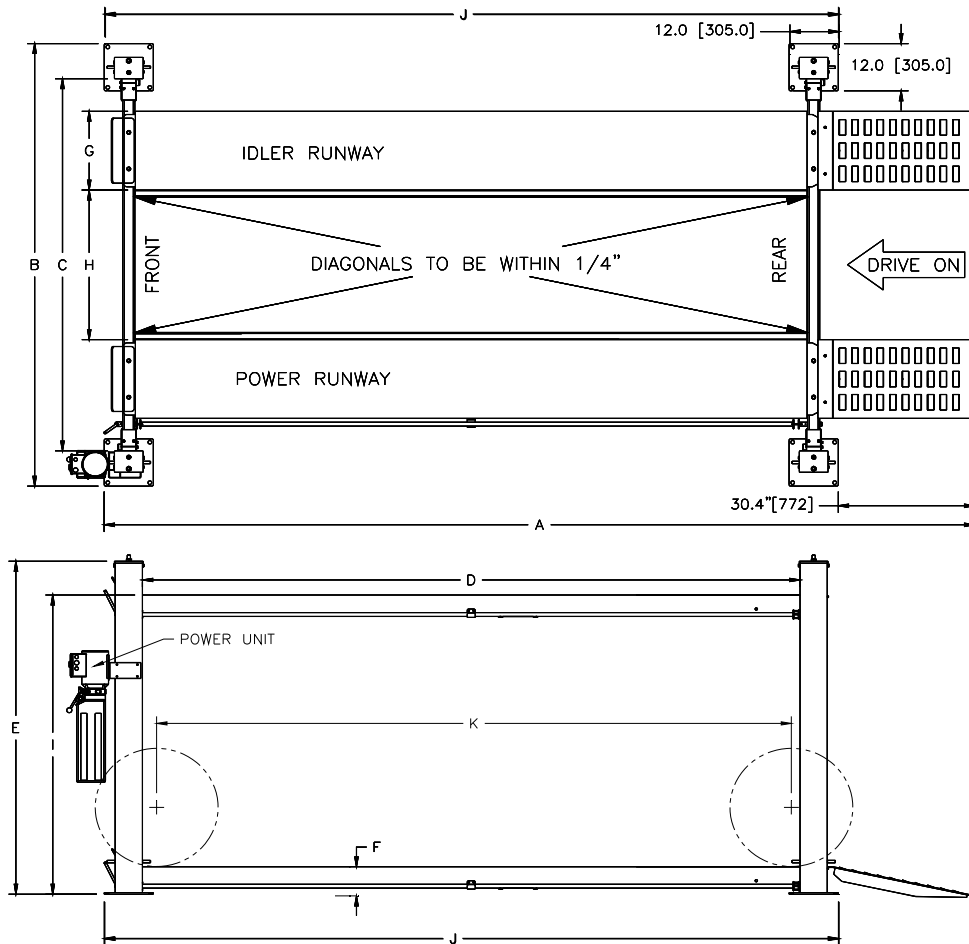

Fig 1 – General Specifications and Service Bay Layout

Models Q4P09H, Q4P09X & Q4P09W
 Installation, Operation and Maintenance

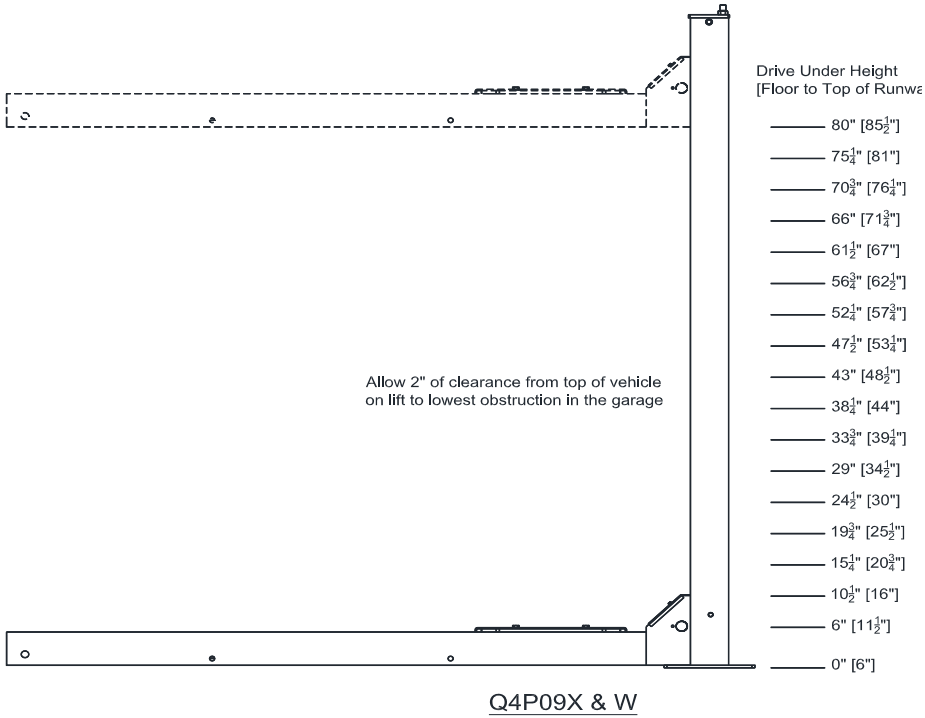
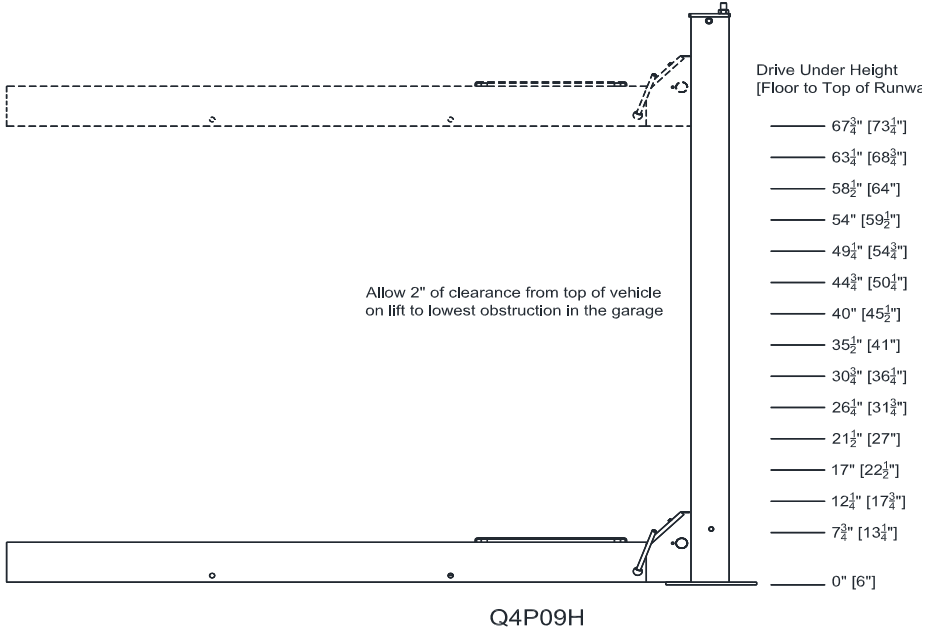

Fig 2 – Drive Under Height

VERTICAL CLEARANCE

Check the height of the area where the lift is to be installed. Clearance should be calculated based on the full raised height of the lift.



WARNING Failure by purchaser to provide adequate clearance could result in unsatisfactory lift performance, property damage, or personal injury.

FLOORING

Be certain you have the proper concrete floor to properly handle the loaded lift. Floor should be in generally good condition with no large cracks, spalling or deterioration.

Minimum requirements for concrete are 4 inches minimum depth, with steel reinforcement, 3500 psi, cured for 28 days per local commercial practice. This lift is designed to accommodate a 3 inch total variation in elevation at the base of the four posts. Floor should be level within 1/2 inch from side-to-side and 2 1/2 front-to-rear to avoid special shimming. No anchors should be installed within 8 inches of any crack, edge, or expansion joint. If these conditions cannot be met, a pad may be poured to accommodate the lift.

Check with local building inspectors and/or permits office for any special instructions or approvals required for your installation.



WARNING Failure by purchaser to provide the recommended mounting surface could result in unsatisfactory lift performance, property damage, or personal injury.

LOCATION

This lift has been evaluated for indoor use only with an operating ambient temp. range of 5 – 40°C (41-104°F)

ELECTRICAL REQUIREMENTS

For lift installation and operation for single phase units, it is necessary to have a dedicated circuit with a single pole (115v) or Double pole (230v) circuit breaker or time delay fuse sized for the following Full Load (FL) Amperage:

**The 115V power unit FL amperage is 15 amps.
The 230V power unit FL amperage is 18 amps.**

For lift installation and operation with standard power unit, it is necessary to have a dedicated 115V single-phase 60-cycle circuit with a 20 amp circuit breaker or time delay fuse

For lift installation and operation with 230V power unit, refer to **Fig 24**.

SAFETY NOTICES AND DECALS

For your safety, and the safety of others, read and understand all of the safety notices and decals included here.

READ ENTIRE MANUAL BEFORE ASSEMBLING, INSTALLING, OPERATING, OR SERVICING THIS EQUIPMENT.

PROPER MAINTENANCE AND INSPECTION IS NECESSARY FOR SAFE OPERATION.

DO NOT OPERATE A DAMAGED LIFT.

Safety decals similar to those shown here are found on a properly installed lift. Be sure that all safety decals have been correctly installed on the Power Unit reservoir. Verify that all authorized operators know the location of these decals and fully understand their meaning. Replace worn, faded, or damaged decals promptly.



WARNING Do not attempt to raise a vehicle on the lift until the lift has been correctly installed and adjusted as described in this manual.

SAFETY INSTRUCTIONS

If attachments, accessories or configuration modifying components that are located in the load path, affect operation of the lift, affect the lift electrical listing or affect intended vehicle accommodation are used on this lift and, if they are not certified for use on this lift, then the certification of this lift shall become null and void. Contact the participant for information pertaining to certified attachments, accessories or configuration modifying components.

www.autolift.org ©2007 by ALI, Inc. ALI / WLSIAO1

<p>SAFETY INSTRUCTIONS</p> <p>Read operating and safety manuals before using lift.</p>	<p>SAFETY INSTRUCTIONS</p> <p>Proper maintenance and inspection is necessary for safe operation.</p>	<p>WARNING</p> <p>Clear area if vehicle is in danger of falling.</p>	<p>WARNING</p> <p>Remain clear of lift when raising or lowering vehicle.</p>
<p>SAFETY INSTRUCTIONS</p> <p>Do not operate a damaged lift.</p>	<p>The messages and pictographs shown are generic in nature and are meant to generally represent hazards common to all automotive lifts regardless of specific style.</p> <p>Funding for the development and validation of these labels was provided by the Automotive Lift Institute, PO Box 33116 Indianapolis, FL 32903.</p> <p>They are protected by copyright. Set of labels may be obtained from ALI or its member companies.</p> <p>© 1992 by ALI, Inc. ALI/WLS200a</p>	<p>WARNING</p> <p>Keep clear of pinch points when lift is moving.</p>	<p>WARNING</p> <p>Keep feet clear of lift while lowering.</p>
<p>CAUTION</p> <p>Lift to be used by trained operator ONLY.</p>	<p>CAUTION</p> <p>Authorized personnel only in lift area.</p>	<p>WARNING</p> <p>Do not override self-closing lift controls.</p>	<p>WARNING</p> <p>Chock wheel to prevent vehicle movement.</p>
<p>The messages and pictographs shown are generic in nature and are meant to generally represent hazards common to all automotive lifts regardless of specific style.</p> <p>Funding for the development and validation of these labels was provided by the Automotive Lift Institute, PO Box 33116 Indianapolis, FL 32903.</p> <p>They are protected by copyright. Set of labels may be obtained from ALI or its member companies.</p> <p>© 1992 by ALI, Inc. ALI/WLS200b</p>	<p>The messages and pictographs shown are generic in nature and are meant to generally represent hazards common to all automotive lifts regardless of specific style.</p> <p>Funding for the development and validation of these labels was provided by the Automotive Lift Institute, PO Box 33116 Indianapolis, FL 32903.</p> <p>They are protected by copyright. Set of labels may be obtained from ALI or its member companies.</p> <p>© 1992 by ALI, Inc. ALI/WLS200c</p>		

Receiving

The shipment should be thoroughly inspected as soon as it is received. The signed bill of lading is acknowledgement by the carrier of receipt in good condition of shipment covered by our invoice.

If any of the goods called for on this bill of lading are shorted or damaged, do not accept them until the carrier makes a notation on the freight bill of the shorted or damaged goods. Do this for your own protection.

NOTIFY **Quality Lifts** AT ONCE if any hidden loss or damage is discovered after receipt.

IT IS DIFFICULT TO COLLECT FOR LOSS OR DAMAGE AFTER YOU HAVE GIVEN THE CARRIER A CLEAR RECEIPT.

File your claim with **Quality Lifts** promptly. Support your claim with copies of the bill of lading, freight bill, and photographs, if available.

Component Packing List

ITEM #	QTY/ LIFT	DESCRIPTION
1	1	IDLER RUNWAY ASS'Y
2	1	POWER RUNWAY ASS'Y
3	1	POWER COLUMN ASS'Y
4	3	IDLER COLUMN ASS'Y
5	2	ENTRANCE RAMP
6	2	CROSS BEAM ASS'Y
7	1	POWER UNIT
8	2	FRONT WHEEL STOP
9	2	REAR WHEEL STOP
10	1	MECHANICAL LOCK BAR
11	8	SHIPPING HARDWARE
12	2	SHIPPING BRACKET WELD

INSTALLATION

SAFETY REQUIREMENTS FOR INSTALLATION AND SERVICE

Refer to ANSI/ALI ALIS (current edition)

IMPORTANT: Always wear safety glasses while installing lift.

TOOLS (MINIMUM REQUIRED)

- a. Tape measure, 25ft.
 - b. Chalk line.
 - c. 4ft level.
 - d. 10" & 12" adjustable wrench.
 - e. Standard open end wrenches.
 - f. 6mm allen wrench.
 - g. Box knife.
 - h. Thread locking compound.
 - i. Needle nose pliers.
 - j. Hammer drill with 3/4" diameter carbide tipped bits (*Optional*).
 - k. 2lb hammer.
 - l. Torque wrench: 150 foot pounds minimum with 1 1/8" socket (*Optional*).
 - m. 8 ft. Step ladder.
 - n. Blocking – (4) 4x4x30", (4) 1x4x12".
 - o. Transit for leveling alignment lift.
 - p. Power Unit requires three gallons of clean 10wt anti-foam anti-rust hydraulic oil or Dexron III ATF.
- DO NOT USE OILS WITH DETERGENTS**

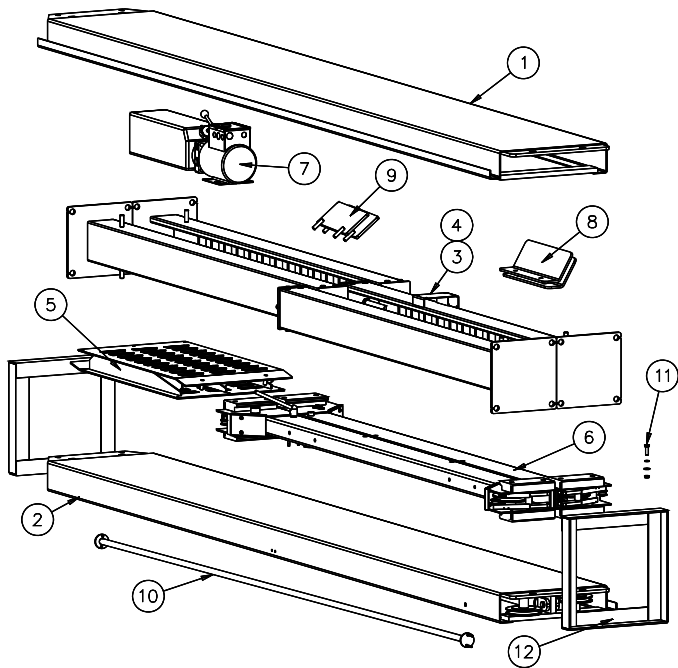

Fig 3 – Package Components

Edition of Standards Referenced

Where any ANSI standard is referenced within this manual, the most recent edition approved by the American National Standards Institute, Inc. shall apply.

LAYOUT

- 1) Lay out the service bay according to the architect's plans or owners instructions (*see Fig 1*). Be certain that the proper conditions exist, see pages 2 & 3.
- 2) Unpack lift. Remove all packaging from Power Runway (power runway has four cable sheaves at rear end) and pull threaded cable ends out. Make sure the cables are in the proper sheaves at the 4-stack, **Fig 6**.

- 3) Remove the mechanical lock release bar from the Idler Runway.
- 4) Check the lock release bar to ensure it is secure and that the lock pawl is in the correct position as shown in **Fig 4**. Adjust if necessary. Verify the lock moves freely and make sure the lock pawl return spring doesn't over-travel and interfere with Lock Ladder.

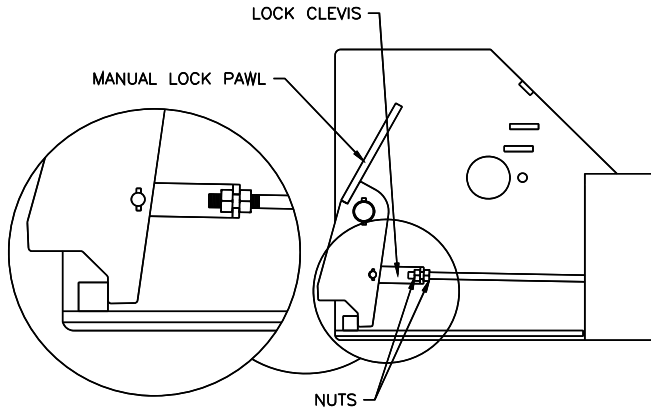

Fig 4 – Lock Clevis

COLUMNS

- 5) Disassembly each column assembly place the columns close to each corner per layout (column with the power unit bracket goes at the front left column per **Fig 1**).
- 6) With the runways spaced per **Fig 1** and blocked per **Fig 7**, using four 30" long 4x4's spanning the width of the runway and four 12" long 1x4's to shim up the jack-rail side of the runway.
- 7) Lay the cross beams on the runway per **Fig 5**. Place cardboard between the runway and cross beam. Slide the column over the ends of the slide blocks on the cross beam. Repeat for each column.
- 8) With help, stand up the front and rear column/cross beam assemblies.

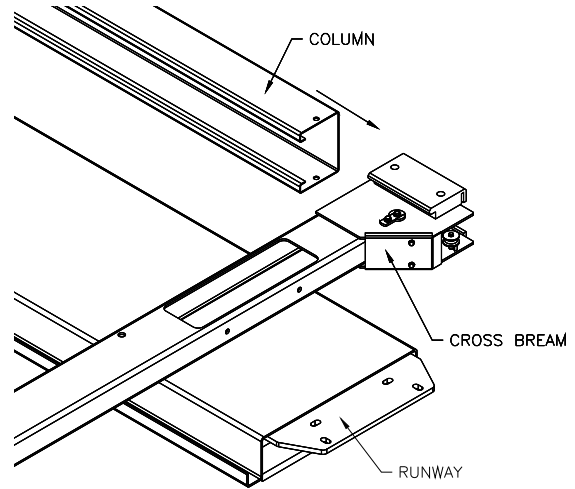

Fig 5 – Column/Cross Beam Assembly

RUNWAY LAYOUT

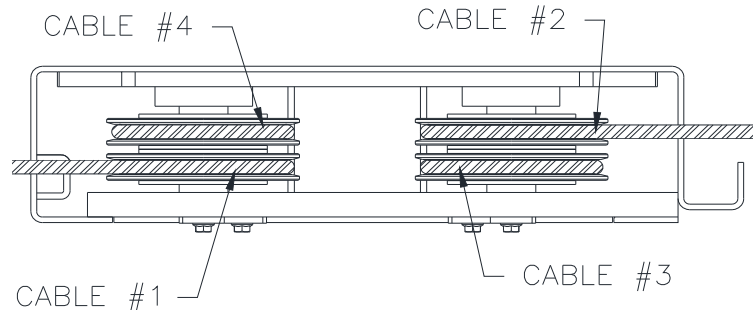

Fig 6 – Power Runway 4-Stack (Rear View)

- 9) Remove the plastic caps from the hydraulic bulkheads on the power runway and extend the hydraulic cylinder fully. Take care not to kink the cables.

NOTE: The cylinder can be extended by pulling on the cylinder pull bar or by applying pressure to the return port, per Fig 8.

- 10) Cable #1 & #2 should be extending out from the rear of the power runway and cable #3 & #4 from the front of the power runway, **Fig 7**.

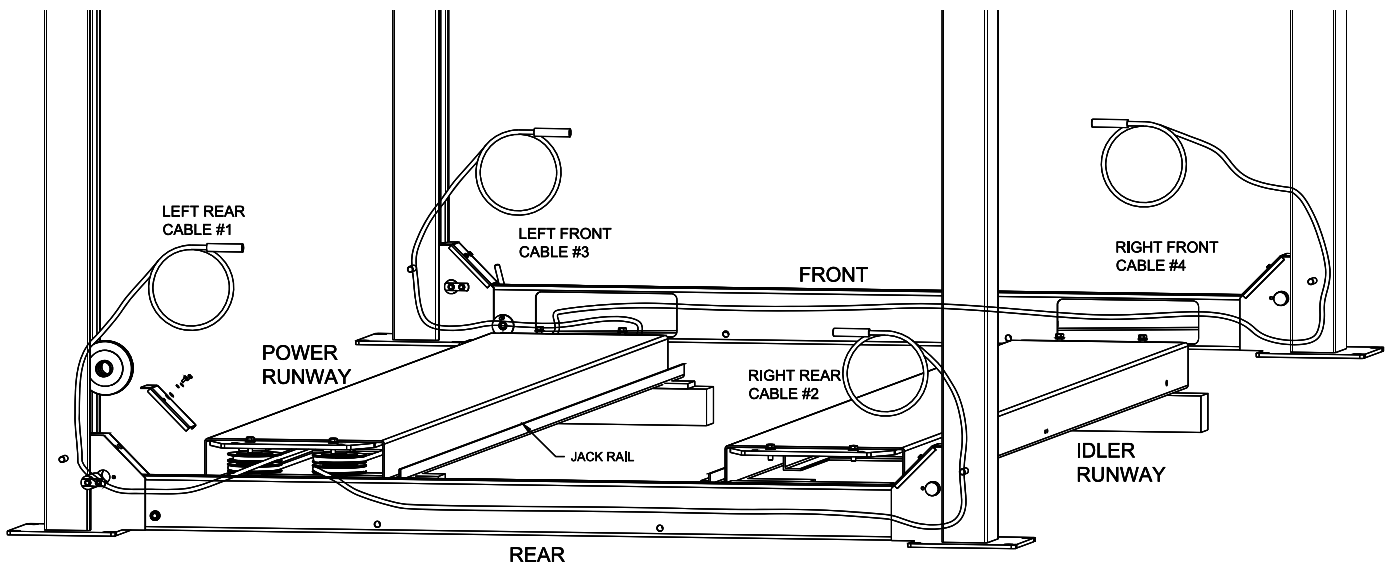

Fig 7 – Runway Layout

- 11) Position the front and rear cross beams, **Fig 7**.

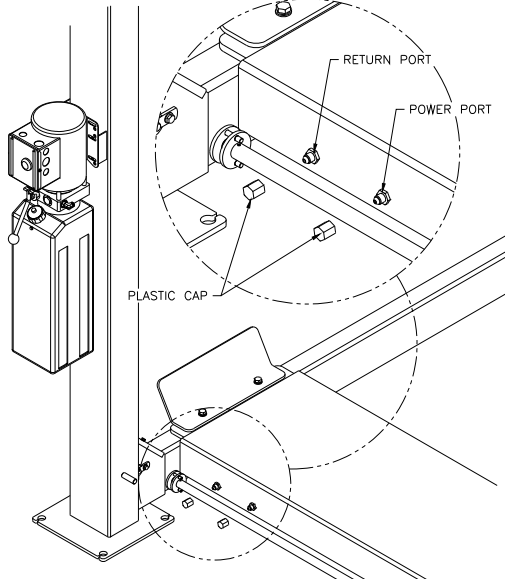

Fig 8 – Hydraulic Ports

- 12) Remove the four (4) cross beam sheaves (one sheave from each end). The runway sheave pins do not need to be removed.
13) Place the mechanical lock release rod into the saddle on the idler side of the cross beam, **Fig 9**.

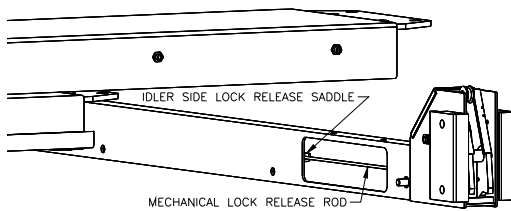

Fig 9 – Mechanical Lock Rod



WARNING

MAKE SURE THE CABLES ARE NOT TANGLED WITH THE LOCK RELEASE ROD INSIDE THE CROSSBEAM.

- 14) From the rear, route cable #1 from the top of the left sheave stack through the access hole and up out the left end of the rear cross beam. Repeat for cable #2 from the bottom of the right rear sheave stack through the access hole and up out the right rear of the rear cross beam, **Fig 6 & 7**.
15) At the rear of the power runway, continue routing cables #3 & #4 to the front of the power runway sheaves, **Fig 10**.
16) At the front of the power runway continue routing cable #3 around the sheave and out the front drivers side cross beam. Cable #4 should be routed around the sheave & out to the passenger side front cross beam, **Fig 11**. **Ensure that cables 3 and 4 are not crossed inside the front cross beam.**

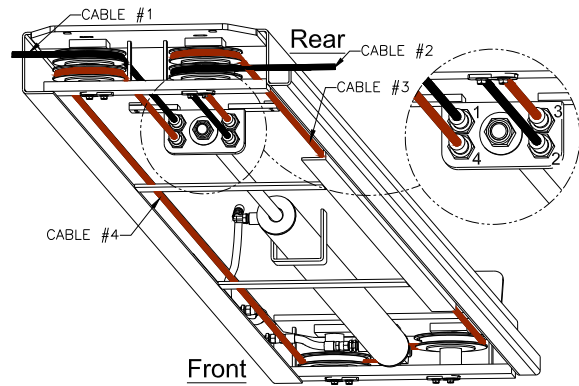

Fig 10 – Cable Layout

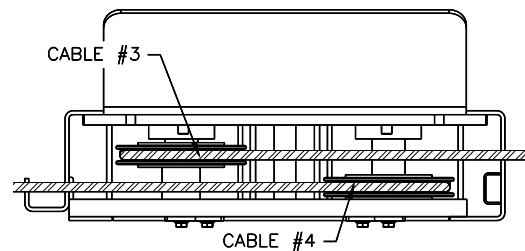

Fig 11 – Power Runway (Front View)

- 17) With runways and cross beams loose, attach the mechanical lock bar to both cross beams with the supplied hardware. Tighten once cross beams are attached to the runways. **Verify the mechanical lock release moves freely and lock pawl return spring doesn't interfere with Lock Ladder. (See Fig 4)**
18) Reinstall the cross beam sheaves with one plastic bearing washer and spacer on each side of each sheave. Make sure the cables are routed correctly around the slack cable latch roller, per **Fig 12**.

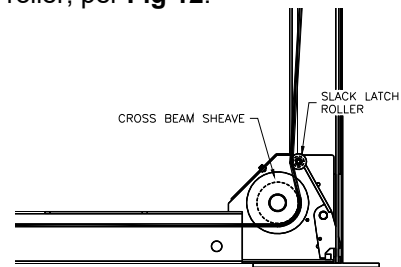

Fig 12 – Slack Cable Routing

- 19) Attach both cross beams to the runways with M12 x 35mm lg. bolts, lock washers and washers (two at each end of each runway). Install front wheel stops at the front of both runways. Do not torque bolts yet.

- 20) Check the layout of the lift in the bay. If anchoring the lift, this is the last chance to make adjustments. Adjust the position of the runways so the distance from power side jack rail to idler side jack rail is the same at the front and the rear and the diagonal measurements from the front tip of one rail to rear tip of the opposite rail are within 1/4", **Fig 13**.

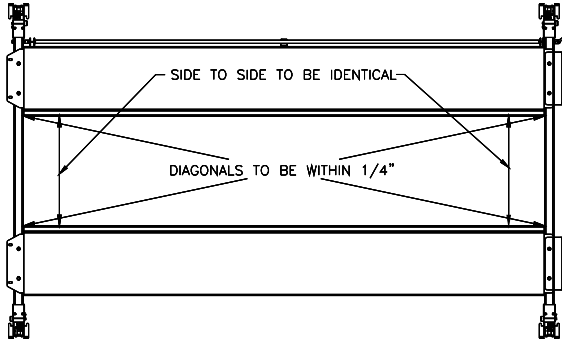

Fig 13 – Final Runway Positioning

- 21) Center cross beam bolts with slots in runway and tighten. (Be careful not to move runways.)
22) Reassembly the lock ladder and top cap to column. Note: the lock ladder is offset from the center of the threaded rod, and orientate per **Fig 14**.

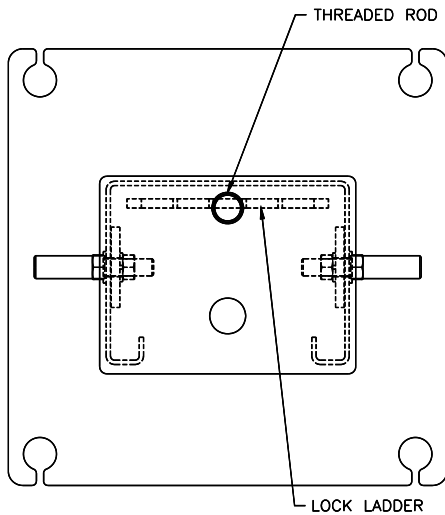

Fig 14 – Locking Ladder Orientation

- 23) Adjust the lock ladder so about 1 1/2" remains sticking out of the top. Tighten both bolts as shown in **Fig 15** when ladder is properly orientated. Note: When adjusting the lock ladder it may be necessary to loosen or remove the bolts holding the top cap to the column so the bottom nut can be adjusted.

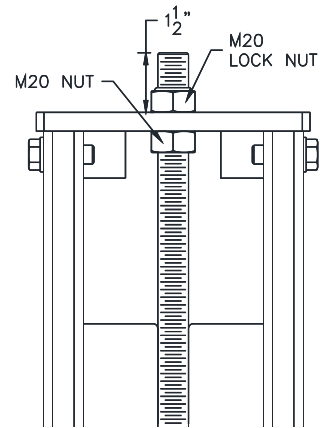

Fig 15 – Lock Ladder Assembly

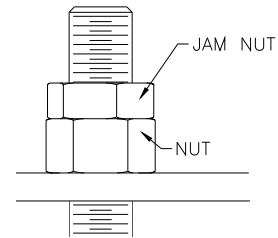

Fig 16 – Cable Jam Nut

- 24) Secure the cables to the top of the column with the nut and jam nut provided, **Fig 16**.
25) Repeat for the remaining three columns.

ANCHORING (OPTIONAL)

NOTE: Lift must be anchored in place if slope is grater then 1/8" per 1 foot.

- 26) The anchor bolts must be installed at least 8" from any crack, edge, or expansion joint.
27) Use a concrete hammer drill with a 3/4 inch carbide bit. Tip diameter should conform to ANSI Standard B212.15 (.775 to .787). Do not use excessively worn bits or bits which have been incorrectly sharpened. A core bit may be necessary if an obstruction is encountered. **Never substitute with shorter anchor.**
28) Drill the anchor holes using the base plate as a template. Drill through the floor if possible or to a depth of 5 inches minimum.
29) Vacuum dust from the hole for proper holding power.
30) Shim columns to plumb using the shims provided or steel washers. **DO NOT** shim more than 1/2" at any given point. Use a level no less than 24" in length to plumb columns.
31) Assemble washer and nut to anchor with nut just below impact section of bolt. Drive anchor into hole until nut and washer contact base. Tighten anchor bolts and recheck column for plumb. Re-shim as required.

NOTE: Level bubble should not only be between the lines, the bubble should be centered between the lines. If shims do not allow sufficient centering of the bubble, it is best to lean the rear columns in the direction toward each other and the front columns in the direction toward each other.

- 32) Install the four cable ends with one lock nut, and one jam nut.

Power Unit

- 33) Install the Power Unit to the column using the supplied M8x20mm bolts and M8 nuts. The power unit can be installed on either the front or side of the power column to suit install location, shown in Fig 17.

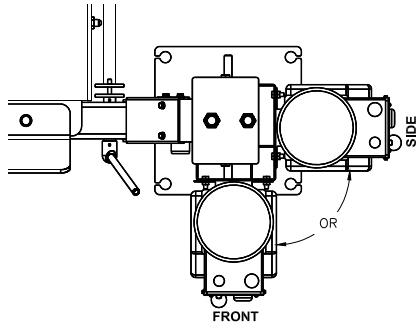

Fig 17 – Power Unit

- 34) For installs on the front of the column (Fig 18), route the power unit supply line to the bulkhead shown below. Attach the 90 degree fitting at a slight angle downward and secure the hose to the fitting.

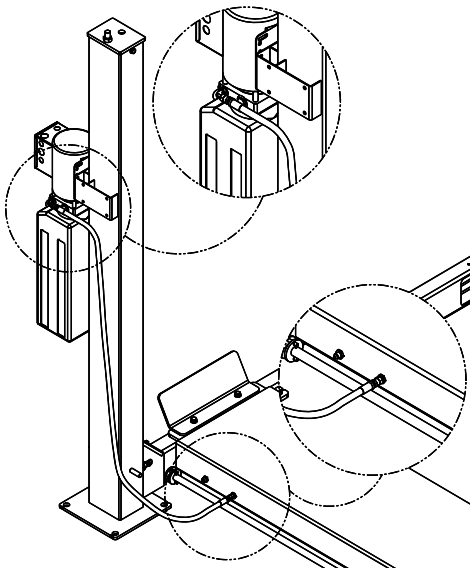

Fig 18 – Supply Line, Front

- 35) Remove the 3/8-18 NPT plug on the side of the power unit and attach the 90 degree elbow at a slightly downward angle. Secure the hose to the bulkhead shown in Fig 19.

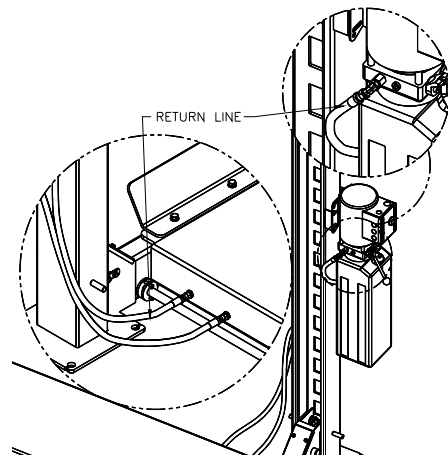

Fig 19 – Return Line, Front

- 36) For installs with the power unit on the side of the column route the supply line to the bulkhead shown in Fig 20.

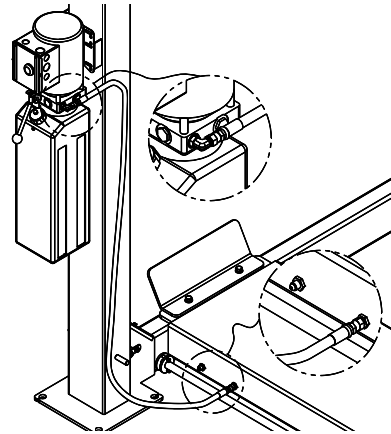

Fig 20 – Supply Line, Side

- 37) Remove the 3/8-18 NPT plug on the side of the power unit and attach the 90 degree elbow, Fig 21.

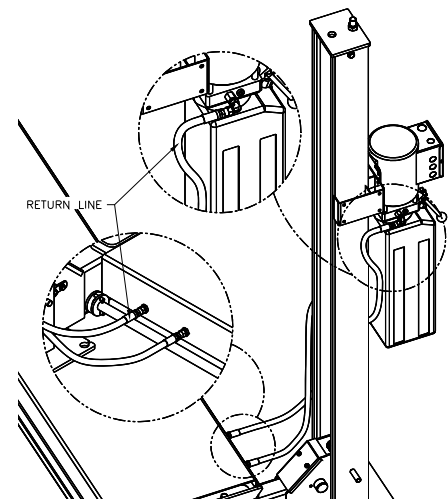

Fig 21 – Return Line, Side

NOTE: When attaching the return line to the bulk head in the runway, make sure it is securely attached at the power unit, and the hose is not twisted or kinked into a position that will lead to getting caught on the power unit reservoir or the stud on the column sides. Raise the lift and carefully watch the path the hose is riding up the column, adjust connection at the power unit and/or runway bulkhead to allow the hose to move up between the power unit and column. Make sure the hose doesn't catch on the column caster lug as the lift rises.

- 38) Install O-Ring end of the straight hydraulic fitting (9/16-18 O-Ring x M14x1.5-6g) to power unit output port. Connect the hydraulic hose to the hydraulic bulkhead fitting in the power runway.

Do Not Use Teflon Tape or Pipe Dope on fittings.

- 39) Connect the power unit to a suitable electrical power source. The standard power unit is 115 volt 50/60 Hz single phase requiring a dedicated 15 amp single throw circuit breaker to operate lift at full capacity.
- 40) **BE CERTAIN ALL FITTINGS AND CONNECTIONS ARE TIGHT. IT IS THE INSTALLERS RESPONSIBILITY TO INSURE SYSTEM IS LEAK-FREE.** Fill the Power Unit with three gallons of clean 10wt anti-foam anti-rust hydraulic oil or Dexron III ATF. **DO NOT USE OILS WITH DETERGENTS.**
- 41) Energize the power unit and raise the lift approximately 1 ft off the ground and look underneath the power runway to verify that the cable lugs are resting firmly against the cylinder pull bar.
- 42) To level the runways and crossbeams use a 4 ft. level. With the lift resting in its locks, find the highest corner and adjust the other three column ladder bars until the runways are level front-to-rear and side-to-side. Tighten jam nut against bottom side of each column top plate.
- 43) Adjust cables until all four locks are synchronized when lift is raised. Tighten cable jam nuts against adjustment nuts.
- 44) Raise and lower lift several times to bleed hydraulic cylinder. Hydraulic cylinder is self-bleeding. Lower lift and check fluid level in reservoir. Add fluid as needed.
- 45) Run lift to full rise and continue running motor approximately 5 more seconds. Check hydraulic hose and connections for leaks. Retighten fitting if leaking.

COLUMN DECAL PLACEMENT

- 46) Center the decal on the front drivers side column and rear passenger side column.
- 47) Apply decal 4" from top of columns, **Fig 22**.

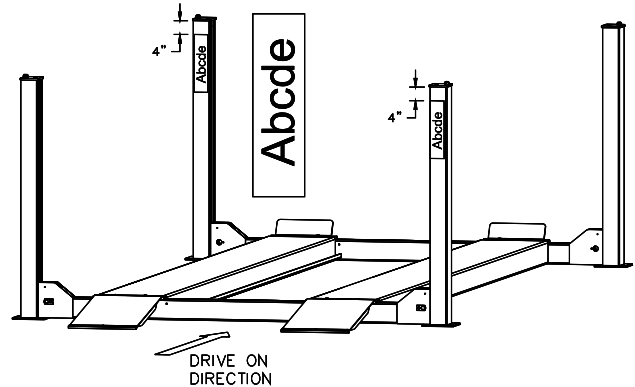

Fig 22 – Decal Placement

- 48) Place the Caution, Warning and Safety Instructions decals seen on page 4, on the power unit as shown, **Fig 223**.

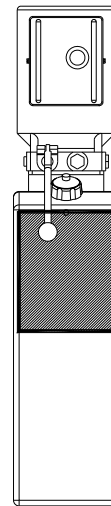

Fig 23 – Power Unit Decal

OWNER/OPERATOR CHECKLIST

SAVE THESE INSTRUCTIONS deliver them to owner/user/employee along with other materials furnished with this lift.

- 49) Demonstrate the operation of the lift to the owner/operator and review correct and safe lifting procedures using the **Lifting It Right** booklet as a guide.
- 50) Return all provided literature (including this manual) to the literature pack envelope and deliver the envelope to the owner/operator/employer
- 51) Complete the online warranty registration (refer to the included warranty statement).

FOR SINGLE PHASE

EACH LIFT SHOULD HAVE A DEDICATED CIRCUIT WITH A 20 AMP DOUBLE POLE BREAKER OR TIME DELAY FUSE

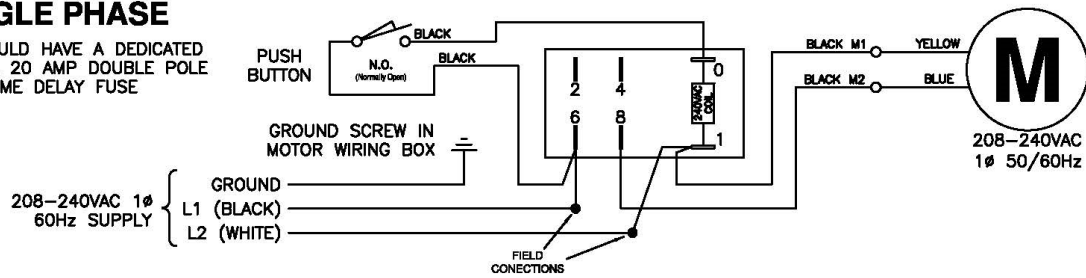

Fig 24 – NON STANDARD 230V WIRING DIAGRAM

OPERATION PROCEDURE

SAFETY NOTICES AND DECALS

This product is furnished with graphic safety warning labels, which are reproduced on page 3 of these instructions. Do not remove or deface these warning labels or allow them to be removed or defaced. For your safety, and the safety of others, read and understand all of the safety notices and decals included.

OWNER/EMPLOYER RESPONSIBILITIES

This lift has been designed and constructed according to ANSI/ALI ALCTV standard. The standard applies to lift manufacturers, as well as to owners and employers. The owner/employer's responsibilities as prescribed by ANSI/ALI ALOIM, are summarized below. For exact wording refer to the actual standard provided with this manual in the literature pack.

The Owner/Employer shall ensure that lift operators are qualified and that they are trained in the safe use and operation of the lift using the manufacturer's operating instructions; ALI/SM, *ALI Lifting it Right safety manual*; ALI/ST, *ALI Safety Tips card*; ANSI/ALI ALOIM, *American National Standard for Automotive Lifts-Safety Requirements for Operation, Inspection and Maintenance*; ALI/WL Series, *ALI Uniform Warning Label Decals/Placards*; and in case of frame engaging lifts, ALI/LP-GUIDE, *Vehicle Lifting Points/Quick Reference Guide for Frame Engaging Lifts*.

The Owner/Employer shall establish procedures to periodically inspect the lift in accordance with the lift manufacturer's instructions or ANSI/ALI ALOIM, *American National Standard for Automotive Lifts-Safety Requirements for Operation, Inspection and Maintenance*; and the employer shall ensure that the lift inspectors are qualified and that they are adequately trained in the inspection of the lift.

The Owner/Employer shall establish procedures to periodically maintain the lift in accordance with the lift manufacturer's instructions or ANSI/ALI ALOIM, *American National Standard for Automotive Lifts-Safety Requirements for*

Operation, Inspection and Maintenance; and the employer shall ensure that the lift maintenance personnel are qualified and that they are adequately trained in the maintenance of the lift.

The Owner/Employer shall maintain the periodic inspection and maintenance records recommended by the manufacturer or ANSI/ALI ALOIM, *American National Standard for Automotive Lifts-Safety Requirements for Operation, Inspection and Maintenance*.

The Owner/Employer shall display the lift manufacturer's operating instructions; ALI/SM, *ALI Lifting it Right safety manual*; ALI/ST, *ALI Safety Tips card*; ANSI/ALI ALOIM, *American National Standard for Automotive Lifts-Safety Requirements for Operation, Inspection and Maintenance*; and in the case of frame engaging lift, ALI/LP-GUIDE, *Vehicle Lifting Points/Quick Reference Guide for Frame Engaging Lifts*; in a conspicuous location in the lift area convenient to the operator.

IMPORTANT SAFETY INSTRUCTIONS

When using your garage equipment, basic safety precautions should always be followed, including the following:

1. Read all instructions.
2. Care must be taken as burns can occur from touching hot parts.
3. To reduce the risk of fire, do not operate equipment in the vicinity of open containers of flammable liquids (gasoline).
4. Keep hair, loose clothing, fingers, and all parts of body away from moving parts.
5. Use only as described in this manual. Use only manufacturer's recommended attachments.
6. ALWAYS WEAR SAFETY GLASSES. Everyday eyeglasses only have impact resistant lenses, they are not safety glasses.

SAVE THESE INSTRUCTIONS

LIFTING A VEHICLE

Place entrance ramps in the slotted holes on the front of the ramp. Drive vehicle onto lift. Set the parking brake. Remove entrance ramps before lifting, and install removable wheel stops with Wheel Side decal as shown in Fig 25.

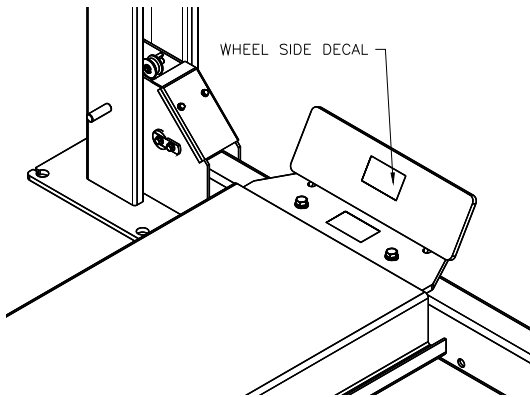

Fig 25 – Removable Wheel Stops

When the vehicle has reached the desired working height, release the power pack button, and lower the vehicle until the safety locks are engaged. The vehicle should remain level when all locks are engaged. If one side engages and the other continues to descend, stop lowering the vehicle, raise it several inches, and try again to engage locks.

IMPORTANT, before walking under the lift ensure that all locks are properly engaged.

It is not safe to work under the vehicle unless all locks are engaged, and the vehicle is level.

LOWERING A VEHICLE

Ensure that the area under the vehicle is clear of personnel and tools.

Raise the vehicle until locks are free.

Disengage the locks by rotating the mechanical lock handle clockwise.

Lower the vehicle by depressing the lowering valve handle and continue to hold mechanical lock handle to keep locks disengaged. Watch lift to insure that the lift is lowering evenly. If not, raise lift and check all locks to insure they are disengaged before trying to lower lift again.

Continue to lower the vehicle until the crossbeams stop against the base plate. It is important to fully lower the lift to release hydraulic pressure on the system.

LOSS OF POWER

If for any reason, the lift will not raise off the locks or the locks will not retract, consult factory authorized personnel.

DO NOT OVERRIDE ANY SAFETY FEATURE IN AN ATTEMPT TO LOWER THE LIFT.

MAINTENANCE

To avoid personal injury, permit only qualified personnel to perform maintenance on this equipment. Maintenance personnel should follow lockout/tagout instructions per ANSI Z244.1.

The following maintenance points are suggested as the basis of a routine maintenance program. The actual maintenance program should be tailored to the installation and include a record of each planned maintenance activity and repair maintenance activity performed. Refer to the maintenance section of the ANSI/ALI ALOIM booklet (blue book) provided with the lift.

- If lift stops short of full rise or chatters, check fluid level and bleed both cylinders per Installation Instructions.
- Replace all Safety, Warning or Caution Labels if missing or damaged. (See *Installation instructions page 3.*)

Daily

- Keep lift components clean.
- Check for loose or broken parts.
- Check hydraulic system for fluid leaks.
- Check lock release activation.

Weekly

- Check cables and sheaves for wear or damage. Replace as required with genuine **Challenger Lifts, Inc.** parts.
- Inspect lock mechanism for proper function.

Monthly

- Torque concrete anchor bolts to 80 ft-lbs.
- Clean and inspect cables and sheaves for wear or damage. Lubricate cables and sheaves with light oil.
- Visually inspect concrete floor for cracks and/or spalls within 12" of base plate

IMPORTANT! Failure to keep lift free of corrosive agents and solvents will lead to reduced service life, which could result in property damage and/or personal injury.

If any problems are encountered, contact your local service representative.

OIL DRIP TRAY (Q4P09DT)

- 1) Place drip tray between runways in the Jack rail, **Fig 26**.
- 2) Slide along jack rail until its in desired location.

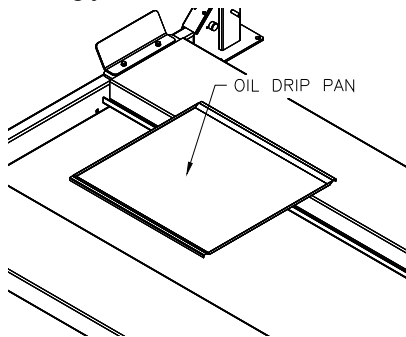

Fig 26 – Oil Drip Tray

STORAGE PLATFORM (Q4P09SP) CAPACITY 1000LBS

- 1) Up to four Storage Platforms can be placed between the runways, **Fig 27**.

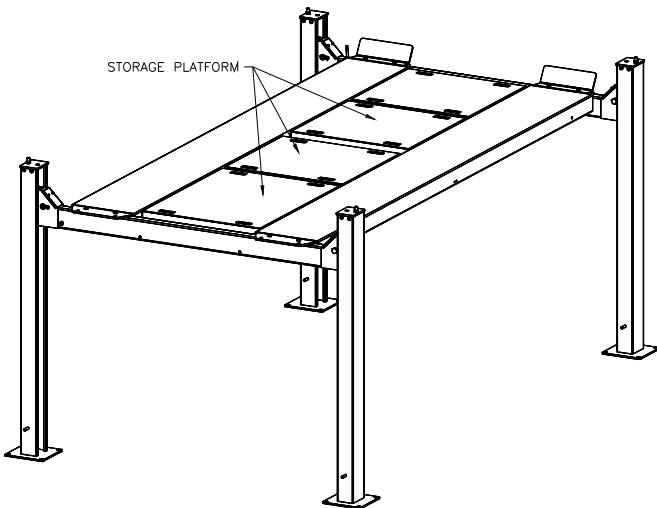

Fig 27 – Storage Platform

JACK TRAY (Q4P09JT), CAPACITY 4500LBS

- 1) The Jack Tray rests on the jack rails between the runways. It can be positioned as needed along the rail, **Fig 28**.

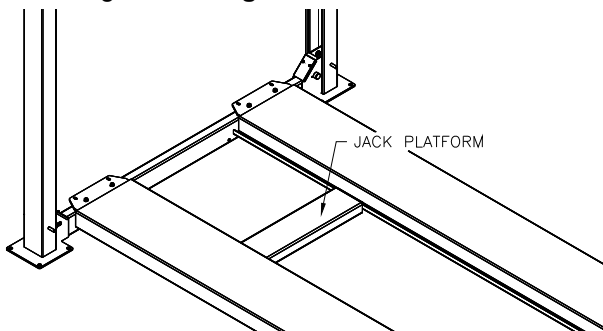

Fig 28 – Jack Tray

MOBILITY KIT (Q4P09CS)

- 1) This set of four casters when attached to the cross beams of an unloaded lift, **Fig 29**, pick the lift up and allow it to be rolled to a different location.

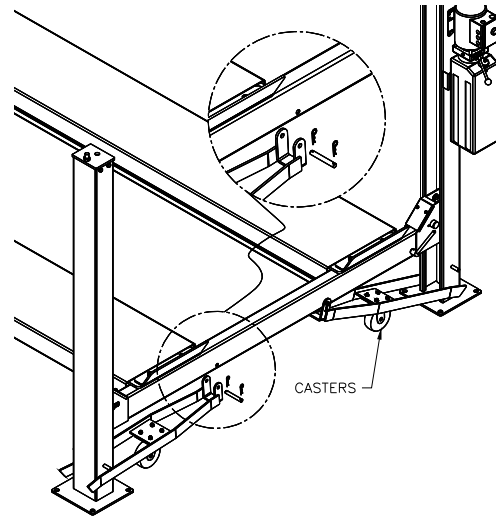

Fig 29 – Mobility Kit

HAND OPERATED ROLLING JACK (QRJ04H)

- 1) Move the jack into under vehicle and extend the arms to the pick up points.
- 2) Make sure the lowering valve is closed all the way by turning the knob clockwise, **Fig 30**.
- 3) Raise vehicle desired height, rest the jack in one of the jack locks.
- 4) To lower, pump the jack to raise it enough to disengage the lock, and turn the lowering knob counter-clockwise.

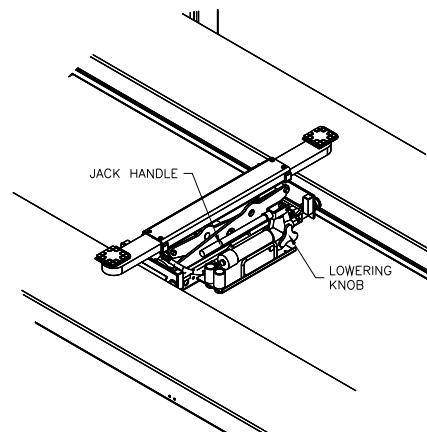

Fig 30 – Rolling Jack

EXTENDED ALUMINUM RAMPS (Q4P09ER)

- 1) Install in the runway by placing the two studs in the slotted holes.
- 2) Remove before raising the lift.

PIVOTING RAMP (Q4P09PR OPTIONAL)

- 1) Raise the lift to a comfortable working height and set into the locks.
- 2) Remove the M12 bolt, lock washer & washer attaching the runway to the crossbeam, and retain the lock washer & washer for installation of the pivot ramp base.
- 3) Install the pivoting ramp base with two M12 x 40mm Lg. and two M12x35mm Flange head bolts, washers and nuts provided in the kit, and the lock washer and washer from the previous step, **Fig 31**. Note the location of flange head bolt in Fig 31. Repeat for other runway.

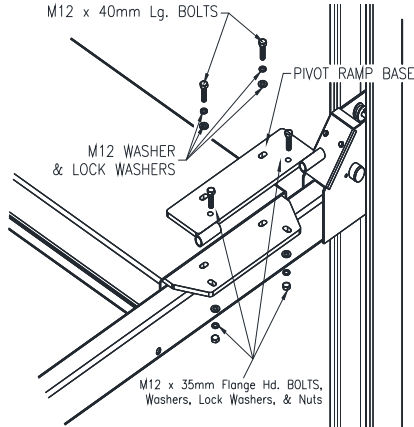

Fig 31 – Base Installation

- 4) Turn the ramp over and install the ramp rotation stop as shown in **Fig 32**. Use the provided M12 x 30mm Lg. bolt and M12 nut.
- 5) Place the stop on the gusset as shown in **Fig 32**, assembly the nut onto the bolt prior to installing the bolt into the stop. Torque the bolt against the ramp gusset and lock into place with the nut.

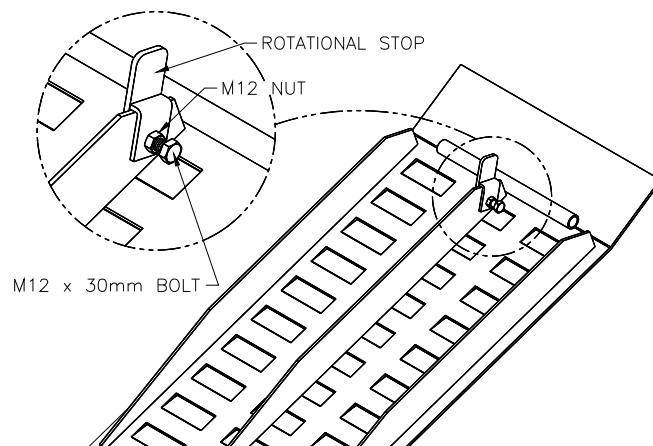

Fig 32 – Rotational Stop

- 6) Assemble the ramp to the base with the ramp hinge pin. Use the provided cotter pins to secure the pin in place, **Fig 33**.

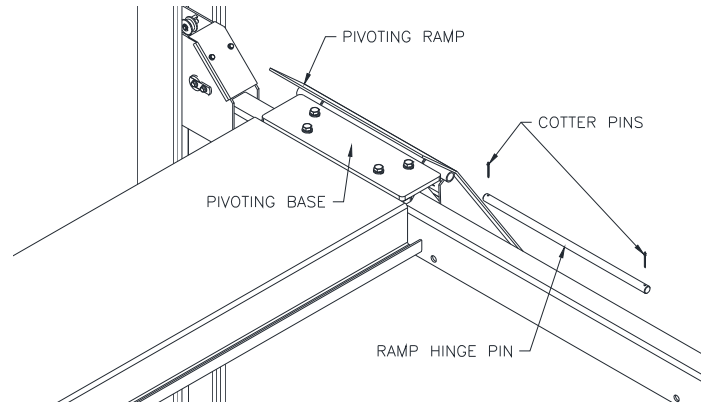
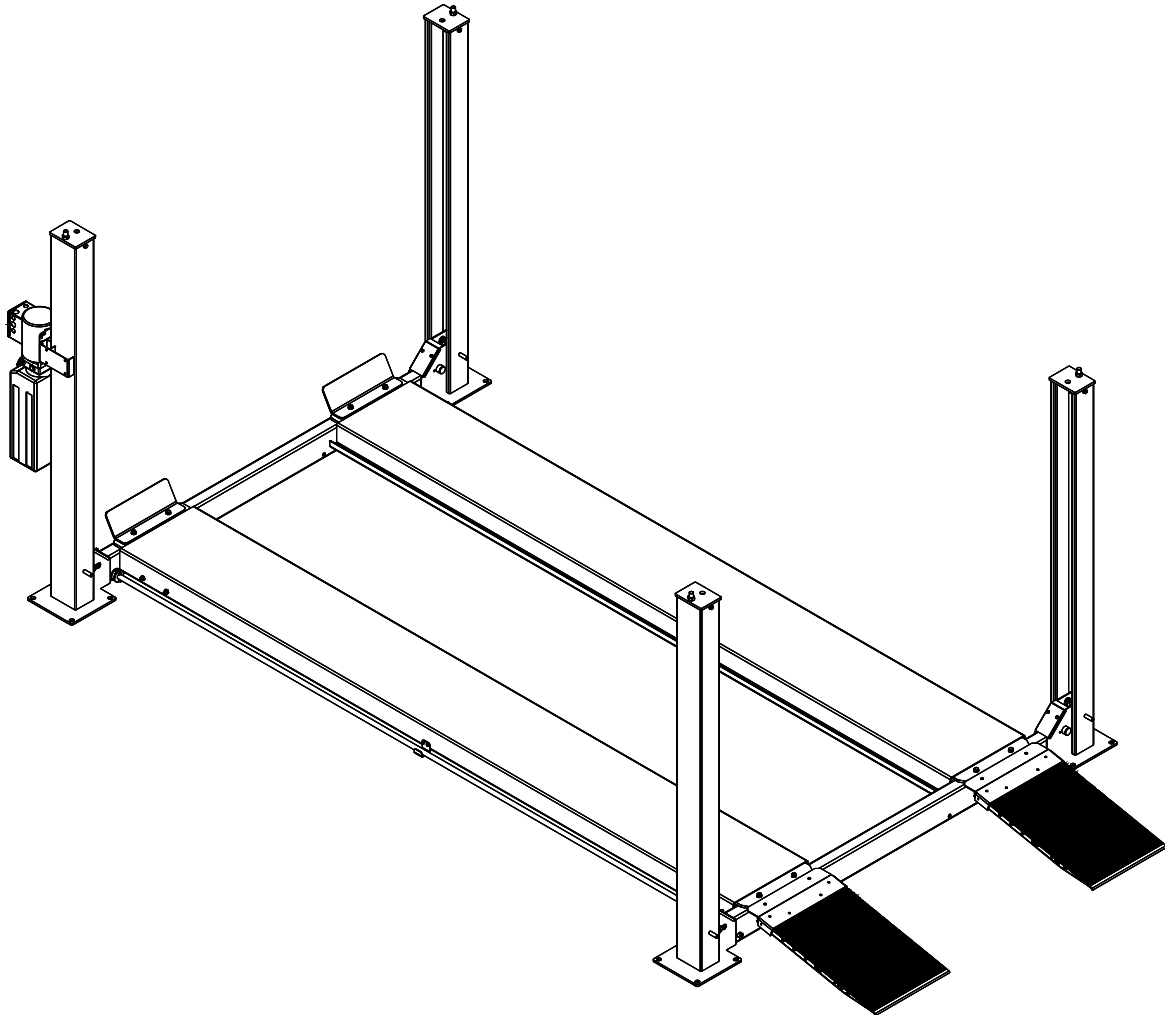

Fig 33 – Ramp Installation

Parts Breakdown

Models Q4P09H, Q4P09X & Q4P09W



IMPORTANT!!!

Replace all worn or broken parts with genuine **Quality Lifts Inc.** parts.
Contact your local Quality Lifts Parts Distributor for pricing and availability.
(Call Quality Lifts Inc. (502) 583-5438 for the Parts Distributor in your area)

Parts Breakdown

Fig A. General Layout

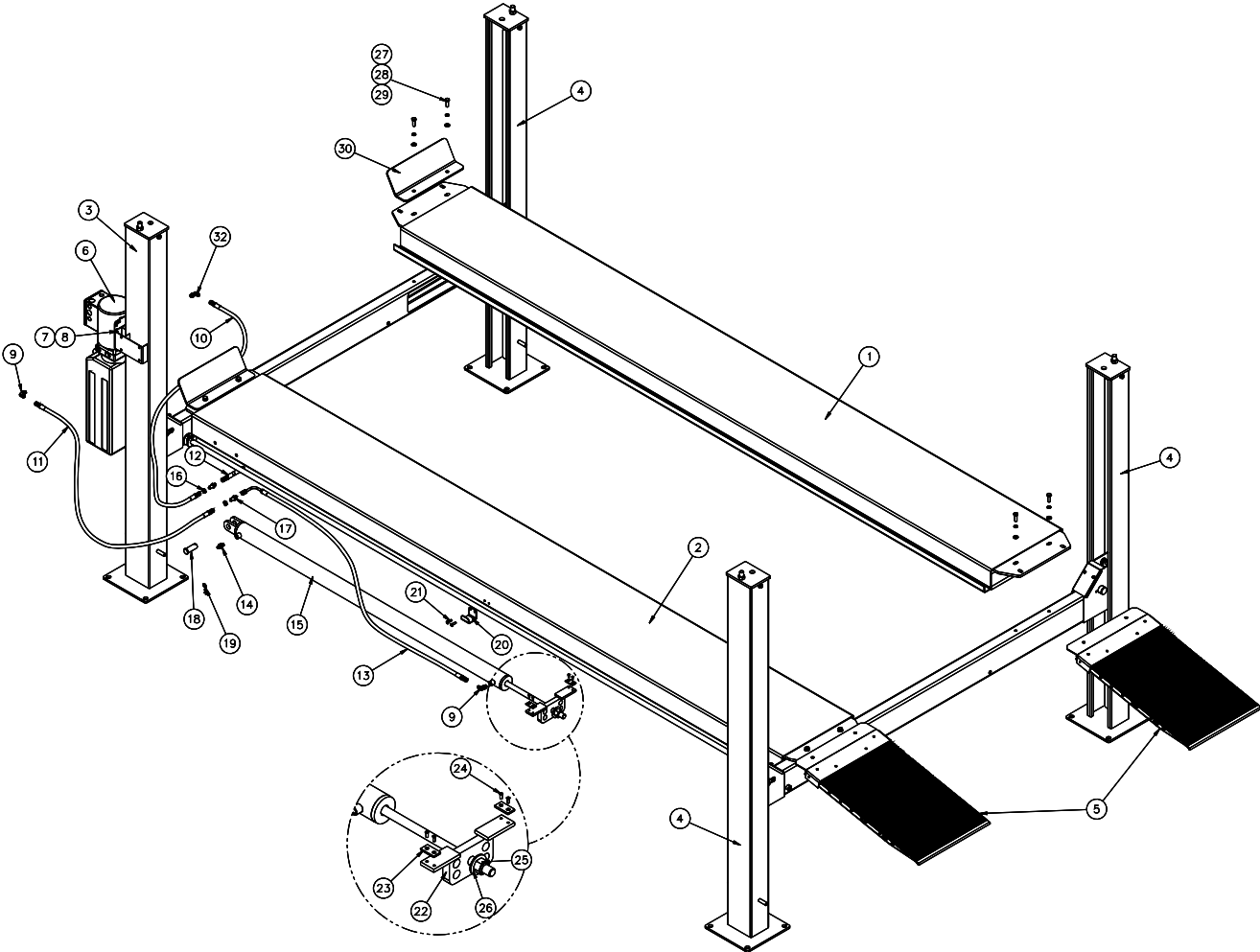

Models Q4P09H, Q4P09X & Q4P09W
Installation, Operation and Maintenance

ITEM #	PART #	QTY/LIFT	DESCRIPTION	
1	TCS4-08-01-00A	1	IDLER RUNWAY WELD	(Q4P09H)
	TCS4A-08-01-00			(Q4P09X & W)
2	TCS4-07-01-00A	1	POWER RUNWAY WELD	(Q4P09H)
	TCS4A-07-01-00			(Q4P09X & W)
3	TCS4-01-00-xx	1	POWER COLUMN ASSY -xx = COLOR CODE	(Q4P09H)
	TCS4A-01-00-xx			(Q4P09X & W)
4	TCS4-02-00-xx	3	IDLER COLUMN ASSY -xx = COLOR CODE	(Q4P09H)
	TCS4A-02-00-xx			(Q4P09X & W)
5	TCS4-09-00D	2	ENTRANCE RAMP (use p/n Q4P09SR for one pr of std ramps/ p/n Q4P09ER for pr Long ramps)	
6	AB-7816-1-DLH	1	POWER UNIT, 115v, SINGLE PHASE, 50/60Hz	
	AB-9367-DLH			POWER UNIT, 220v, SINGLE PHASE, 50/60Hz
7	X10-048	4	M8 NUT	
8	MR6-007	4	M8 x 20mm Lg. HEX HD CAP SCREW	
9	TCS4-13	2	9/16 O-RING x M14x1.5 90 DEGREE HYD. FITTING	
10	TCS4-15	1	HOSE – RETURN (91")	
11	JSZ5-5-10-04	1	HOSE – SUPPLY (67")	
12	TCS4-07-08	1	HOSE – SHORT RETURN	
13	JSZ5-5-10-03	1	HOSE - HYDRAULIC CYLINDER	
14	TCS4-07-07	1	STRAIGHT HYD. FITTING	
15	TCS4-03-00	1	HYDRAULIC CYLINDER ASSEMBLY	(Q4P09H)
	TCS4A-03-00			(Q4P09X & W)
16	JSZ5-5-10-06	2	M14x1.5 BULKHEAD NUT	
17	JSZ5-5-10-05	2	M14 BULKHEAD FITTING	
18	B40082	1	CLEVIS PIN	
19	B40126	1	1/8 x 1½" Lg. COTTER PIN	
20	TCS4-07-06	1	MECHANICAL LOCK BAR HOLDER	
21	VS10-10-25	2	M8 x 12mm Lg. PHILLIPS PAN HEAD SCREW	
22	TCS4-07-05-00	1	CABLE PULL BAR	
23	JSZ5-5-03-03-03	2	CABLE PULL BAR SLIDE BLOCKS	
24	Q4P09-001	4	M6 x 20mm Lg. COUNTER SUNK SCREWS	
25	Q4P09-002	1	M24 NYLON LOCK NUT	
26	Q4P09-003	1	M24 WASHER	
27	B40083	8	M12 x 35mm Lg. HEX FLG. HD. CAP SCREW	
28	X10-039	8	M12 LOCK WASHER	
29	X10-038	8	M12 WASHER	
30	B40266	2	WHEEL STOP	
31	TCS4-12-00	2	REMOVABLE WHEEL STOP	
32	JSJ3-10-05	1	3/8-18 NPT x M14x1.5 90 DEGREE HYD. FITTING	

Replace all worn or broken parts with genuine **Quality Lifts Inc.** parts.
Contact your local Quality Lifts Parts Distributor for pricing and availability.
(Call Quality Lifts Inc. (502) 583-5438 for the Parts Distributor in your area)

Models Q4P09H, Q4P09X & Q4P09W
Installation, Operation and Maintenance

PARTS BREAKDOWN (continued)

Fig B. Cables

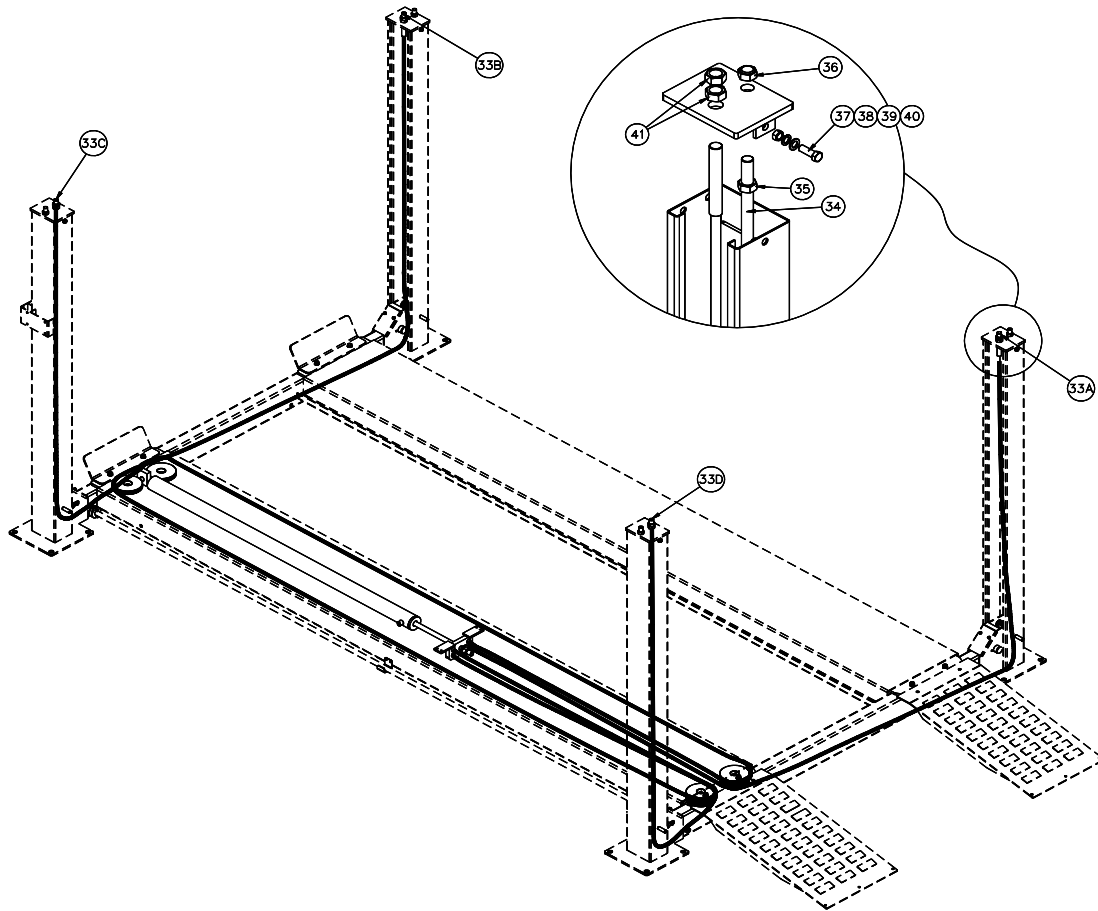

ITEM #	PART #	QTY/LIFT	DESCRIPTION	
33A	TCS4-11-02	1	PASSENGER SIDE REAR CABLE Cable #2	(174 7/8") (Q4P09 H)
	TCS4A-11-02			(187") (Q4P09 X)
	TCS4B-11-02			(194 1/2") (Q4P09 W)
33B	TCS4-11-04	1	PASSENGER SIDE FRONT CABLE Cable #4	(353 5/8") (Q4P09 H)
	TCS4A-11-04			(389 3/4") (Q4P09 X)
	TCS4B-11-04			(397 1/4") (Q4P09 W)
33C	TCS4-11-03	1	DRIVER SIDE FRONT CABLE Cable #3	(295 5/8") (Q4P09 H)
	TCS4A-11-03			(332") (Q4P09 X)
	TCS4B-11-03			(339 1/2") (Q4P09 W)
33D	TCS4-11-01	1	DRIVER SIDE REAR CABLE Cable #1	(117 1/8") (Q4P09 H)
	TCS4A-11-01			(129 1/4") (Q4P09 X)
	TCS4B-11-01			(136 3/4") (Q4P09 W)
34	TCS4-01-03-00	4	LOCK LADDER	(Q4P09H)
	TCS4A-01-03-00			(Q4P09X & W)
35	MR6-005	4	M20 NUT	
36	Q4P09-004	4	M20 LOCK NUT	
37	VS10-40-17	8	M12 x 35mm Lg. HEX FLG. HD. CAP SCREW	
38	X10-038	8	M12 WASHER	
39	X10-039	8	M12 LOCK WASHER	
40	X10-040	8	M12 NUT	
41	Q4P09-010	8	M22x2.5 NUT	

Replace all worn or broken parts with genuine **Quality Lifts Inc.** parts.
Contact your local Quality Lifts Parts Distributor for pricing and availability.
(Call Quality Lifts Inc. (502) 583-5438 for the Parts Distributor in your area)

PARTS BREAKDOWN (continued)

Fig C. Runway Sheaves

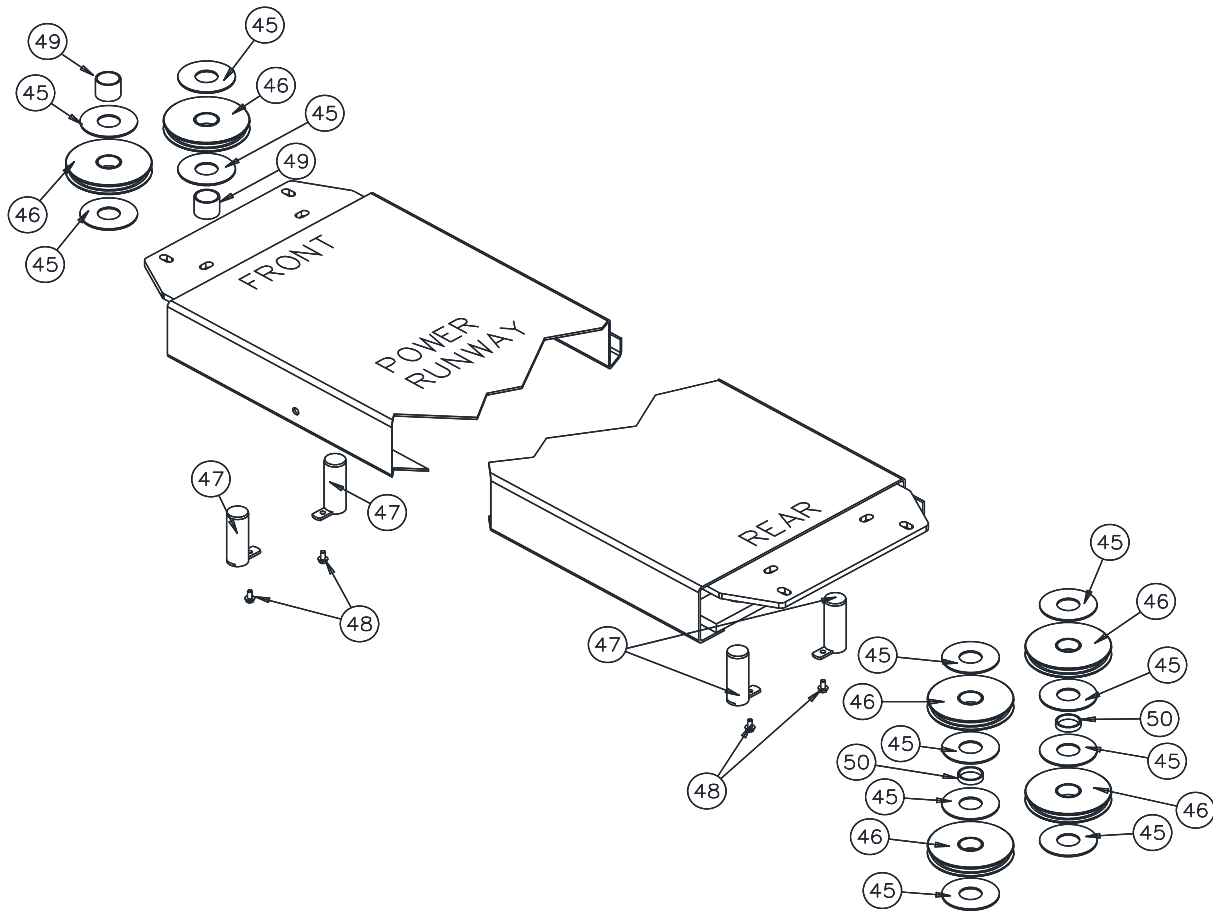

ITEM #	PART #	QTY/LIFT	DESCRIPTION
45	40053	12	1/8" THICK BEARING
46	TCS4-04-03-00	6	SHEAVE ASSEMBLY
47	TCS4-07-04-00	4	SHEAVE PIN ASSEMBLY (RUNWAY)
48	B31188	4	M8 x 16mm Lg. HEX LOCKING FLG. HD. CAP SCREW
49	TCS4-07-03	2	RUNWAY SHEAVE SPACER - TALL
50	TCS4-07-02	2	RUNWAY SHEAVE SPACER - SHORT

Replace all worn or broken parts with genuine **Quality Lifts Inc.** parts.
 Contact your local Quality Lifts Parts Distributor for pricing and availability.
(Call Quality Lifts Inc. (502) 583-5438 for the Parts Distributor in your area)

PARTS BREAKDOWN (continued)

Fig D. Cross Beams

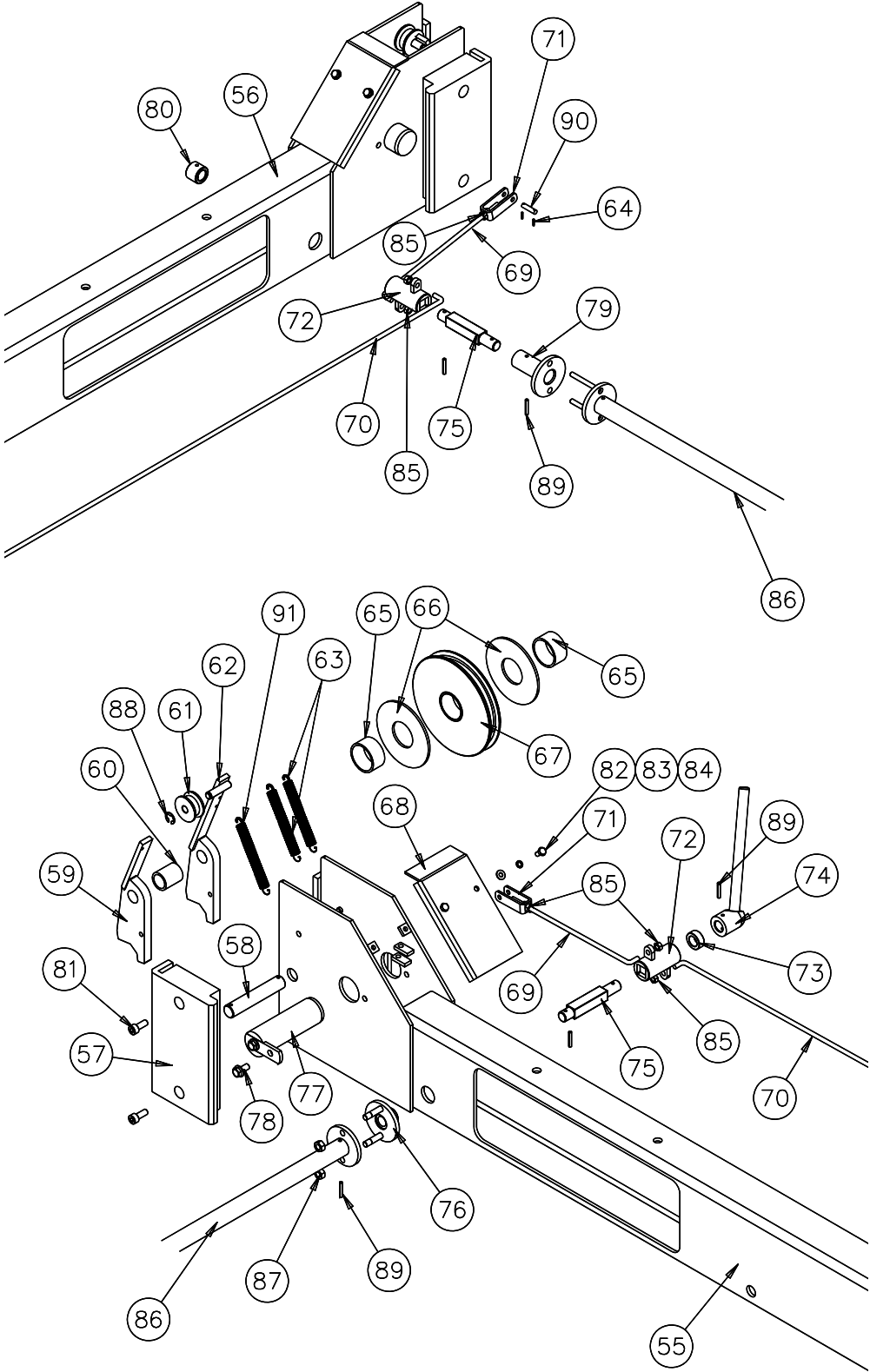

Models Q4P09H, Q4P09X & Q4P09W
Installation, Operation and Maintenance

ITEM #	PART #	QTY/LIFT	DESCRIPTION
55	TCS4-04-01-00A	1	FRONT CROSSBEAM WELD (Q4P09H & X)
	TCS4B-04-01-00		FRONT CROSSBEAM WELD (Q4P09W)
56	TCS4-05-01-00A	1	REAR CROSSBEAM WELD (Q4P09H & X)
	TCS4B-05-01-00		REAR CROSSBEAM WELD (Q4P09W)
57	TCS4-04-02	8	SLIDE BLOCK
58	B40127	4	LOCK PIVOT PIN
59	TCS4-04-11-00	4	PRIMARY LOCK PAWL
60	B40132	4	SPACER BUSHING
61	JSZ5-5-02-05	4	ROLLER
62	B40134	4	SLACK CABLE LATCH
63	JSZ5-5-02-09	8	SLACK LATCH EXTENSION SPRING
64	B40124	4	Hair Pin Cotter Pin
65	B40438-X	8	SHEAVE SPACER BUSHING
66	40053	8	1/8" THICK BEARING
67	TCS4-04-03-00	4	SHEAVE ASSEMBLY
68	TCS4-04-14	4	SHEAVE GUARD
69	TCS4-04-08	2	MECHANICAL LOCK ROD- (Q4P09H & X)
	TCS4B-04-08		SHORT (Q4P09W)
70	TCS4-04-09	2	MECHANICAL LOCK ROD – (Q4P09H & X)
	TCS4B-04-09		LONG (Q4P09W)
71	TCS4-04-06	4	LOCK ROD CLEVIS
72	TCS4-04-07	2	MECHANICAL LOCK COUPLER
73	TCS4-04-05	1	LOCK SPACER
74	TCS4-04-04-00A	1	MECHANICAL LOCK HANDLE
75	TCS4-04-12	2	LOCK COUPLER PIVOT PIN
76	TCS4-04-10-00	1	FLANGE COUPLING – MALE
77	B40116	4	SHEAVE PIN ASSEMBLY (CROSSBEAM)
78	B31188	4	M8 x 16mm Lg. HEX LOCKING FLG. HD. CAP SCREW
79	TCS4-05-10-00	1	FLANGE COUPLING – FEMALE
80	TCS4-05-11	1	RETAINER SLEEVE
81	Q4P09-006	16	M8 x 20mm Lg. SOCKET HEAD CAP SCREW
82	Q4P09-007	8	M6 x 12mm Lg. CAP SCREW
83	X10-33	8	M6 LOCK WASHER
84	X10-032	8	M6 WASHER
85	B40467	12	M6 NUT
86	TCS4-10-00	1	MECHANICAL LOCK (Q4P09H)
	TCS4A-10-00		BAR (Q4P09X & W)
87	GB889-86	4	M10 Nylon NUT
88	Q4P09-008	4	Ø10mm SNAP RING
89	Q4P09-009	4	Ø4mm x 24mm Lg. ROLL PIN
90	B40123	4	Clevis Pin
91	TCS4-04-13	4	PRIMARY LOCK EXTENSION SPRING

Replace all worn or broken parts with genuine **Quality Lifts Inc.** parts.
Contact your local Quality Lifts Parts Distributor for pricing and availability.
(Call Quality Lifts Inc. (502) 583-5438 for the Parts Distributor in your area)

Caster Assembly

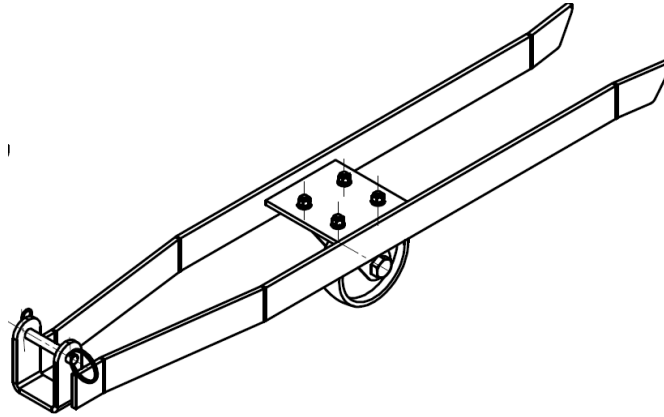

ITEM #	PART #	QTY/ASSY	DESCRIPTION
92	TCS4-06-01-00A	1	Caster Weldment
93	TCS4-06-03	1	Caster Wheel
94	X10-077	4	Bolt, M10 x 25mm Long
95	X10-019	4	Nut, M10
96	X10-073	4	Washer, 10mm
97	TCS4-06-02	1	Pivot Pin
98	GJY12-3	1	Hairpin cotter
99	A1075	1	Pull Ring

REVISIONS

- 2020/08/10 – UPDATED THE 115V POWER UNIT PART NUMBER.
- 2020/10/05 – UPDATED MECHANICAL LOCK COUPLER AND ENTRANCE RAMP PART NUMBER IN THE PARTS BREAKDOWN.
- 2020/12/15 – CHANGED POWER UNIT FORM 31368-19 TO AB-9367/DLH. UPDATED WIRING DIAGRAM AND PARTS BREAKDOWN.
- 2023/10/01 – UPADTED ANSI/ALI REFERENCE MATERIAL. UPDATED ANCHORING REFERENCE MATERIAL. PG. 8.
- 2024/03/25 – ADDED ANSI STANDARDS REFERENCE STATEMENT SECTION. PG. 5.