

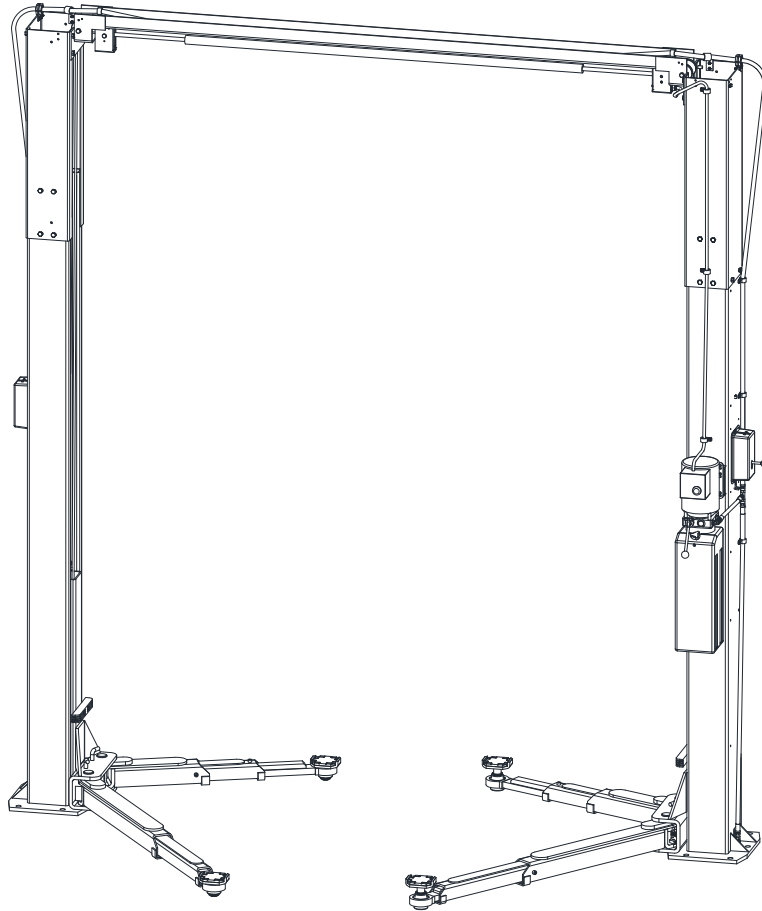

INSTALLATION, OPERATION & MAINTENANCE MANUAL

**Two Post
Surface Mounted Lift**



MODEL EQ10

QUALITY LIFTS, LLC
2311 South Park Rd., Louisville, KY 40219
E-mail: sales@qualitylifts.com
www.qualitylifts.com

IMPORTANT: READ THIS MANUAL COMPLETELY BEFORE
INSTALLING or OPERATING LIFT

GENERAL SPECIFICATIONS

See Figure 1	EQ10
A Overall Height	143 7/8" (3655 mm)
Ceiling Height Required	144" (3658 mm)
B Floor to Overhead Switch	137" (3482 mm)
C Rise Height (Foot Pads Highest Position)	72 1/4" (1899 mm) (75 1/4" (1975 mm) with Adapter)
D Foot Pad Height	4 1/4" (108mm-172 mm)
E Overall Width	131 3/4" (3347 mm)
F Inside of Columns	110 1/4" (2800 mm)
G Drive-Thru Clearance	98 3/8" (2499 mm)
H Short Arm Reach	21 3/4"-39 1/4" (553 mm-998 mm)
I Long Arm Reach	38 1/4"-55 3/8" (971 mm-1407 mm)
* Lifting Capacity * (Hydraulic Pressure at Cap.)	10,000 lbs. [2500 lbs. Per Arm] (2800 psi)
Motor	2HP, Single Phase, 60Hz, 208/230V 2HP, 3 PH, 50/60Hz, 208-230/460V
Speed of Rise **	44 seconds
Lift Approximate Weight	1750 lbs.

* Lift capacity ratings are based on loads equally distributed on all four arms.

** Lifting and lowering speeds may vary depending on the weight of the vehicle.

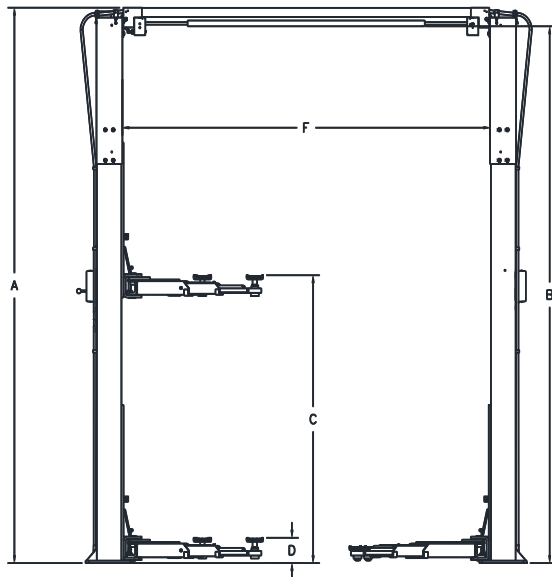

Fig. 1a - General Specifications

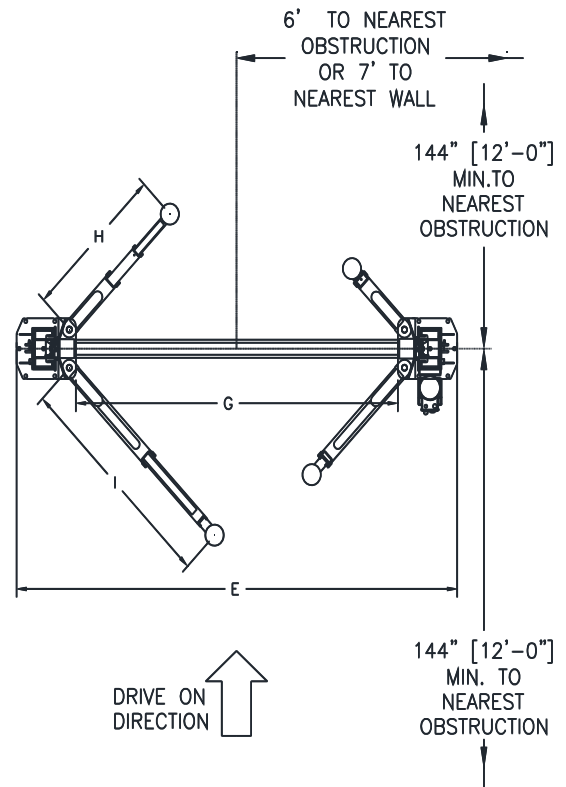

Fig. 1b - Service Bay Layout

VERTICAL CLEARANCE

Check the height of the area where the lift is to be installed. Clearance should be calculated based on the full raised height of the lift.



Failure by purchaser to provide adequate clearance could result in unsatisfactory lift performance, property damage, or personal injury.

FLOORING

Be certain you have the proper concrete floor to properly handle the loaded lift. Floor should be in generally good condition with no large cracks, spalling or deterioration.

Minimum requirements for concrete are 4 inches minimum depth, with steel reinforcement, 3500 psi, cured for 28 days per local commercial practice. Floor should be level within 3/8 inch over the installation area. No anchors should be installed within 8 inches of any crack, edge, or expansion joint. If these conditions cannot be met, a pad may be poured to accommodate the lift.

Check with local building inspectors and/or permits office for any special instructions or approvals required for your installation.

A qualified person should be consulted to address seismic loads and other local or state requirements.



Failure by purchaser to provide the recommended mounting surface could result in unsatisfactory lift performance, property damage, or personal injury.

LOCATION

This lift has been evaluated for indoor use only with an operating ambient temp. range of 5 – 40°C (41– 104°F). Outdoor Installation is Prohibited.

ELECTRICAL REQUIREMENTS

For lift installation and operation, it is necessary to have a dedicated circuit with circuit breaker or time delay fuse. Refer to wiring diagram for circuit sizing.

SAFETY NOTICES AND DECALS

For your safety, and the safety of others, read and understand all of the safety notices and decals included here.

READ ENTIRE MANUAL BEFORE ASSEMBLING, INSTALLING, OPERATING, OR SERVICING THIS EQUIPMENT.

PROPER MAINTENANCE AND INSPECTION IS NECESSARY FOR SAFE OPERATION.

DO NOT OPERATE A DAMAGED LIFT.

Safety decals similar to those shown here are found on a properly installed lift. Be sure that all safety decals have been correctly installed as shown in this manual. Verify that all authorized operators know the location of these decals and fully understand their meaning. Replace worn, faded, or damaged decals promptly.



Do not attempt to raise a vehicle on the lift until the lift has been correctly installed

and adjusted as described in this manual.

<p>NOTICE</p> <p>Read operating and safety manuals before using lift.</p>	<p>NOTICE</p> <p>Proper maintenance and inspection is necessary for safe operation.</p>	<p>If attachments, accessories, or configuration modifying components used on this lift are located in the load path and affect operation of the lift, affect the lift electrical listing, or affect intended vehicle accommodations, and if they are not certified for use on this lift, then the certification of this lift shall become null and void. Contact the participant for information pertaining to certified attachments, accessories, or configuration modifying components.</p> <p>NOTICE</p> <p>www.autolift.org ©2011-2018 by ALL, Inc. ALL/WLSIA01</p>
<p>NOTICE</p> <p>Do not operate a damaged lift.</p>	<p>The messages and graphics shown are generic and are meant to broadly represent hazards common to all automotive lifts, regardless of specific style.</p> <p>Replacement labels may be obtained from the original lift manufacturer and ALL's member companies.</p> <p>Funding for the development and validation of these labels was provided by the Automotive Lift Institute, PO Box 85, Corland, NY 13645. These labels are protected by copyright.</p> <p>www.autolift.org ©2018-2017 ALL/WLS14</p>	

<p>CAUTION</p> <p>Lift to be used by trained operator only.</p>	<p>CAUTION</p> <p>Authorized personnel only in lift area.</p>	<p>WARNING</p> <p>Clear area if vehicle is in danger of falling.</p>	<p>WARNING</p> <p>Position vehicle with center of gravity midway between adapters.</p>
<p>CAUTION</p> <p>Use vehicle manufacturer's lift points.</p>	<p>CAUTION</p> <p>Always use safety stands when removing or installing heavy components.</p>	<p>WARNING</p> <p>Remain clear of lift when raising or lowering vehicle.</p>	<p>WARNING</p> <p>Avoid excessive rocking of vehicle while on lift.</p>
<p>CAUTION</p> <p>Use height extenders when necessary to ensure good contact.</p>	<p>CAUTION</p> <p>Auxiliary adapters may reduce load capacity.</p>	<p>WARNING</p> <p>Do not override self-closing lift controls.</p>	<p>WARNING</p> <p>Keep feet clear of lift while lowering.</p>
<p>The messages and graphics shown are generic and are meant to broadly represent hazards common to all automotive lifts, regardless of specific style.</p> <p>Funding for the development and validation of these labels was provided by the Automotive Lift Institute, PO Box 85, Corland, NY 13645. These labels are protected by copyright. Set of labels may be obtained from ALL or its member companies.</p> <p>©2018 by ALL, Inc. ALL/WLS14</p>		<p>The messages and graphics shown are generic and are meant to broadly represent hazards common to all automotive lifts, regardless of specific style.</p> <p>Funding for the development and validation of these labels was provided by the Automotive Lift Institute, PO Box 85, Corland, NY 13645. These labels are protected by copyright. Set of labels may be obtained from ALL or its member companies.</p> <p>©2018 by ALL, Inc. ALL/WLS14</p>	

RECEIVING

The shipment should be thoroughly inspected as soon as it is received. The signed bill of lading is acknowledgement by the carrier of receipt in good condition of shipment covered by our invoice.

If any of the goods called for on this bill of lading are shorted or damaged, do not accept them until the carrier makes a notation on the freight bill of the shorted or damaged goods. Do this for your own protection.

NOTIFY **Challenger Lifts** AT ONCE if any hidden loss or damage is discovered after receipt.

IT IS DIFFICULT TO COLLECT FOR LOSS OR DAMAGE AFTER YOU HAVE GIVEN THE CARRIER A CLEAR RECEIPT.

File your claim with **Challenger Lifts** promptly. Support your claim with copies of the bill of lading, freight bill, and photographs, if available.

Component Packing List

QTY/ LIFT	DESCRIPTION
1	Power Column Assembly
1	Idler Column Assembly
1	Overhead Assembly
1	Installation Hardware Box
1	Lift Hardware Box
1	Power Column Extension
1	Idler Column Extension
2	Rear Arm Assembly
2	Front Arm Assembly
2	Synchronizer Cable
2	Lock Cover
1	Power Unit – 1 Phase Power Unit – 3 Phase
1	Literature Pack

ACCEPTED OILS – Do not use oils with detergents
Hydraulic fluid is not provided with the lift shipment.

-10 wt. anti-foam, anti-rust hydraulic / biodegradable oil
-Dexron III ATF

Edition of Standards Referenced

Where any ANSI standard or ALI materials are referenced within this manual, the most recent edition shall apply.

INSTALLATION

SAFETY REQUIREMENTS FOR INSTALLATION AND SERVICE

Refer to ANSI/ALI ALIS (current edition)

IMPORTANT: Always wear safety glasses while installing lift.

TOOLS (MINIMUM REQUIRED)

- Tape measure, 16ft
- Chalk line
- 4ft level
- 10" adjustable wrench
- Metric open-end wrenches 10mm, 13mm, 14mm, 15mm, 17mm, 18mm, 19mm and 24mm
- Metric Allen Wrenches 4mm, 5mm, 6mm, and 8mm.
- Needle Nose pliers
- Snap Ring pliers.
- Hammer drill with 3/4" diameter carbide tipped bits.
- 2lb hammer
- Torque wrench: 150 foot-pounds minimum with 1 1/8" socket
- 12 ft. Step ladder
- Anti-Seize lubricant (for arm pins and foot pad screw threads and stop rings)
- Phillips Head Screwdriver

LAYOUT

- Layout the service bay according to the architect's plans or owner's instructions (**see Fig 1b**). **Failure to install in this orientation can result in personal and property damage.** Be certain that the proper conditions exist, see **Pg 3**.
- Attach bolt-on parts to column extensions as shown in **Fig 8** and assemble columns using M12 x 30 Hex bolts. Ensure power extension assembly is bolted to power column. NOTE: Install Nut and Washers on exterior of the assembly.
- Using the Overall Width (C) Dimension from **Fig 1b**, chalk two parallel lines on the floor within 1/8" tolerance. Erect both column assemblies. Align the base plate edges to the chalk lines. See **Fig 2**.

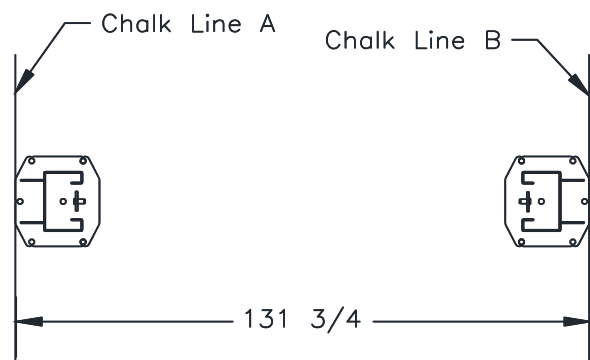

Fig. 2 – Baseplate Layout

ANCHORING

Note:

- The anchor bolts must be installed at least 8" from any crack, edge, or expansion joint. Recheck the area around both base plates.
 - Use a concrete hammer drill with a 3/4-inch carbide bit. Tip diameter should conform to ANSI Standard B212.15 (.775 to .787). Do not use excessively worn bits or bits which have been incorrectly sharpened. A core bit may be necessary if an obstruction is encountered. **Never substitute with shorter anchors.**
- 4) Recheck "Inside of Columns" dimension (**Fig. 1**).
 - 5) Using the base plate as a template, drill one anchor hole. Drill through the floor if possible or to a depth of 5 inches minimum.
 - 6) Clean the hole inside and out.
 - 7) Assemble a washer and nut to the anchor with nut just below impact section of bolt. Drive the anchor into the hole until the nut is 3/4" above the baseplate (leaving room for shims).
 - 8) **Complete steps 5 through 7 for the five (5) anchors (one at a time) around each column.**
 - 9) Shim both columns to plumb using the shims provided as shown in **Fig. 5**. DO NOT shim more than 1/2" at any given point. Use a level no less than 24" in length to plumb columns.
 - 10) Drive all the anchors until nut and washer contact baseplate.

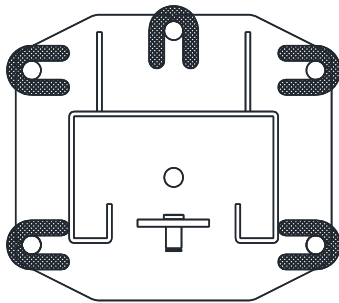

Fig. 3 – Column Shimming

- 11) Tighten power column anchors and recheck column for plumb. Re-shim if necessary. Torque to 150 foot-pounds to set anchors.
- 12) Loosen Idler Column anchors 1/8" and proceed with the Overhead Beam installation.

OVERHEAD/LIMIT SWITCH

- 13) Raise and install Overhead Assembly using M12 x 30 Hex Bolts.
- 14) Install Overhead Limit Switch and Shutoff Bar under the Overhead Beam as shown in **Fig 4**.

- 15) Check idler column shimming. Use additional shims (**see Fig 3**) to remove any gaps that may have been created while installing overhead beam. Tighten anchor bolts and re-check column for plumb. Torque to 150 foot-pounds.

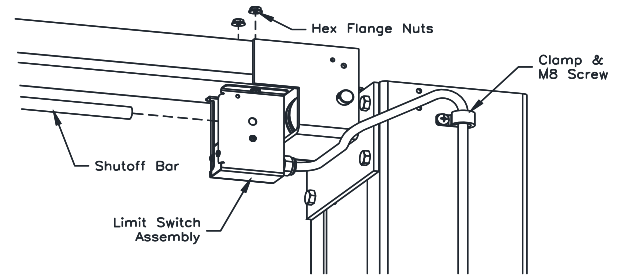

POWER SIDE

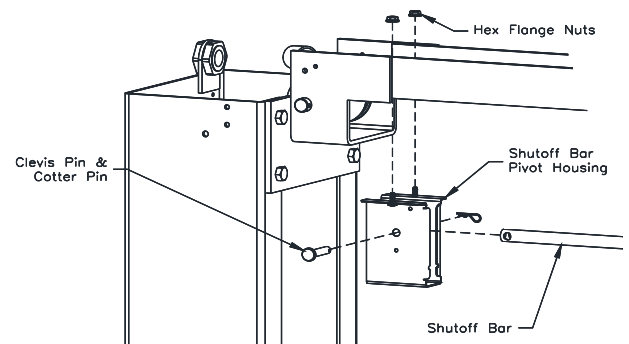

IDLER SIDE

Fig. 4 - Limit Switch

SYNCHRONIZER CABLES

- 16) Manually raise each carriage into the second lock position.
- 17) **IMPORTANT:** Ensure that the lock pawl is engaged by attempting to manually disengage it. When properly engaged, the weight of the carriage will prevent it from moving.
- 18) At the upper beam sheave locations disassemble and reassemble the cable trapping rod to install the cable onto the sheave as shown in **Fig 5**. At base of columns, bottom sheave will need to be removed then reassembled.

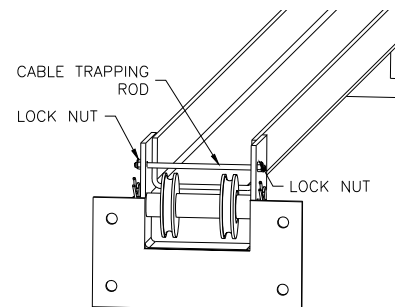

Fig. 5-Cable Trapping

- 19) Attach one end of synchronizing cable to carriage. See **Fig 6** for proper attachment.

- 20) Route cable up and over sheave in overhead. Follow across to other sheave on opposite column. Route down through carriage to sheave in bottom of column. Route under sheave and up to cable attachment. Use **Fig 6** for proper attachment.
- 21) Repeat for opposite side.

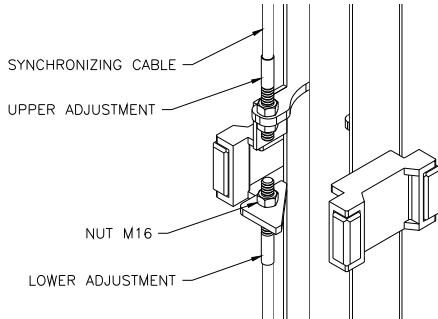

Fig. 6 – Synchronizing Cables

POWER UNIT & HYDRAULIC LINES

- 22) Mount Power Unit to power column as shown in **Fig 7** using (4) M8 hex bolts and nuts.
- 23) Attach hydraulic elbow fitting threading the O-Ring end into the power unit.
- 24) **IMPORTANT – To ensure proper hose fitting seal without damage to the fitting follow this procedure for each hose connection:** Screw flared fitting on finger tight. Rotate flared fitting 1 ½ flats or 90 degrees. Back the flared fitting off one full turn and repeat.
- 25) Thread power unit hose (short) to elbow on power unit.

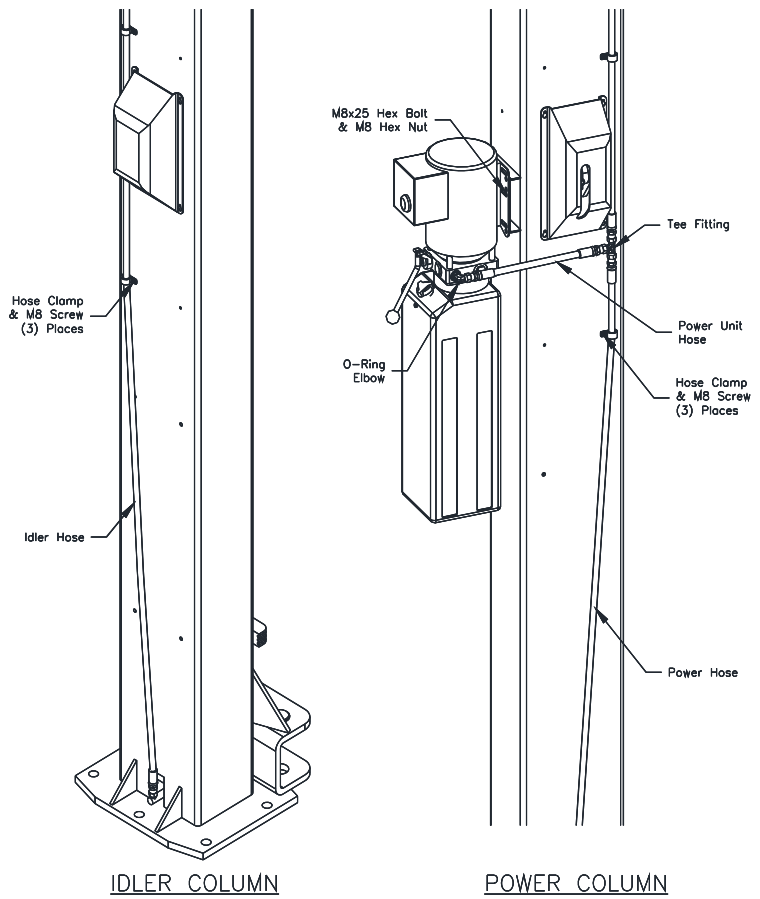

Fig. 7 – Hose Routing

- 26) Beginning on the idler side, attach the idler hose to the cylinder elbow fitting. Route the idler hose (long) up the backside of the column and through the plastic guide at the top of the extension. Continue across the overhead through each of the guides as shown in **Fig 8** and down the backside of the power column.
- 27) Route the power hose from the cylinder elbow fitting to the union tee provided. Connect idler hose and power unit hose to union tee as shown in **Fig 7**.
- 28) Use hose clamps and M8 Screws to secure hydraulic hoses as shown in **Figure 7**.
- 29) **BE CERTAIN ALL FITTINGS AND CONNECTIONS ARE TIGHT. IT IS THE INSTALLERS RESPONSIBILITY TO ENSURE SYSTEM IS LEAK-FREE.** Fill the Power Unit with three gallons of clean 10wt anti-foam anti-rust hydraulic oil or Dexron III ATF. **DO NOT USE OILS WITH DETERGENTS.**

COLUMN EXTENSIONS

30) Use hardware shown in Fig 8 to install bolt-on hose guide components.

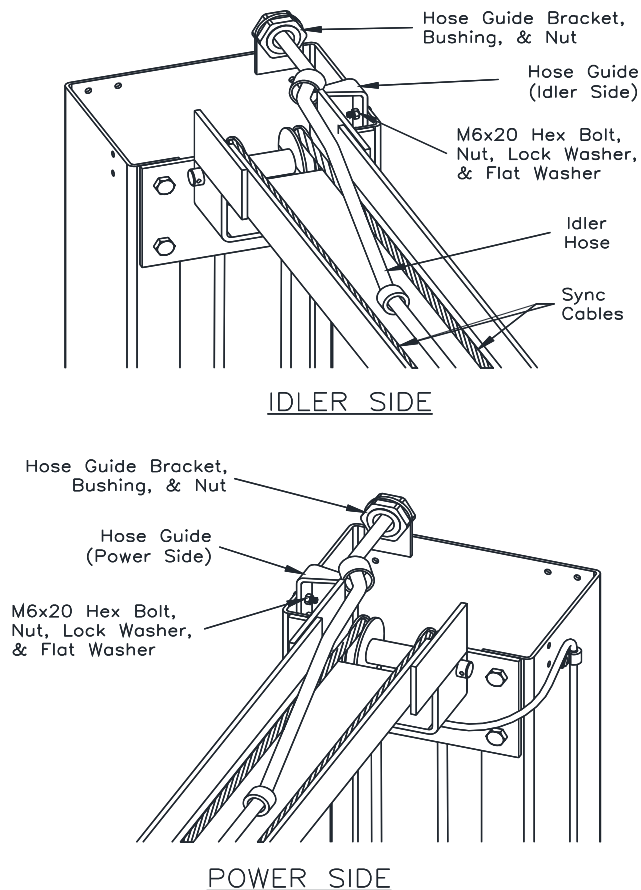

Fig. 8 – Column Extensions

LOCK RELEASE

- 31) Install Lock Release Rod, Clevis, and Knob to the Power Column Lock using one M10 Nut.
- 32) Attach Mechanical Lock Release Cable Assembly to each lock pawl. See Fig 9.

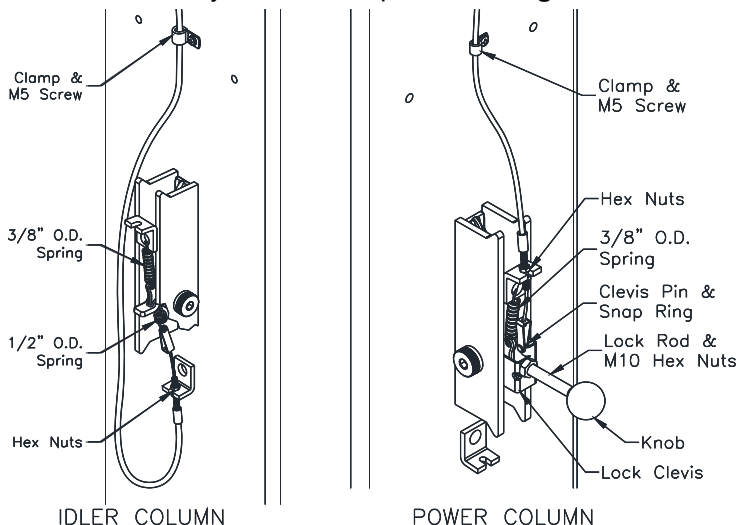

Fig. 9 – Lock Assembly

33) Secure Lock Release Cable at the top of each column extension as shown in Fig 10. Lock Release Cable should be routed on the opposite side of the Overhead Beam as the Idler Hose to prevent interference.

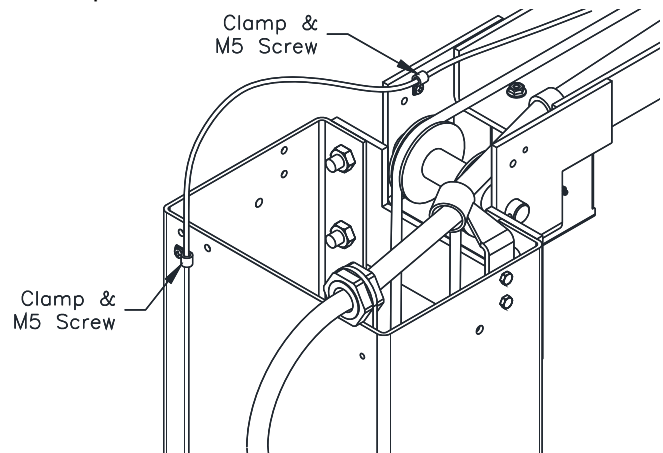

Fig. 10 – Lock Cable Routing

THE LOCK RELEASE CABLE ADJUSTMENT IS NOT COMPLETE UNTIL THE LIFT HAS BEEN LOWERED AND “FINAL ADJUSTMENTS” HAVE BEEN MADE.

ARM INSTALLATION

34) Lubricate the arm pin or carriage arm pin hole with “anti-seize” and install the arms as shown in Fig 11. Once the set screw is finger tight against the arm pin, tighten 1/4 turn with hex key.

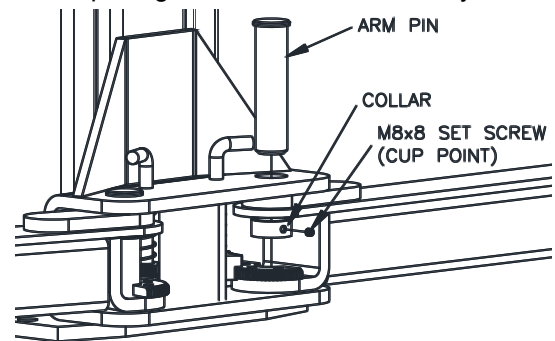

Fig. 11 –Arm Install

- 35) Ensure that the arm restraint gears engage and disengage properly. Arm restraints should disengage when lift is fully lowered. If any binding occurs, ensure that the large gear mounted to the arm has been factory installed tight against the arm pin.
- 36) Extend the footpad to both extents and apply anti-seize to the three retaining rings and where the double screw makes contact with the base of the footpad.
- 37) Ensure arm stop hardware is present and adequately tightened so that spring lock washer is fully compressed for each arm. Slide all the arms out so they are fully extended making sure that the male is retained in the female.

- 38) Check arm stop engagement by fully extending each arm. Properly installed arm stop hardware will prevent arm from becoming over-extended and possibly disassembled.



Loose or missing arm stop hardware may result in personal injury and/or property damage.

ELECTRICAL

- 39) Refer to **Fig 13 Wiring Diagram** for all steps under this heading.

Single Phase

- 40) Connect the Overhead Limit Switch Cord to Power Unit as shown.
41) Connect Power Unit to suitable electrical source as shown.

Three Phase

- 42) Power unit is factory wired for 240 volts. Refer to wiring diagram or motor plate for optional voltages.
43) Connect Contactor Enclosure to column. Mounting hardware should be centered on the column side to side to avoid the path of the slide blocks.
44) Connect Overhead Limit Switch Cord to Contactor as shown.
45) Connect Contactor to Power unit as shown. Connect Contactor to suitable electrical source as shown.

IMPORTANT: AFTER WIRING HAS BEEN COMPLETED, TEST OPERATION OF POWER UNIT & OVERHEAD LIMIT SWITCH. WHILE RAISING LIFT, OPERATE OVERHEAD SHUTOFF BAR. POWER UNIT MOTOR SHOULD STOP WHEN SHUTOFF BAR IS RAISED.

COLUMN DECAL PLACEMENT

- 46) Clean the surface of the columns before placing the decals.
47) Apply the Safety Decals (Pg. 3) below the lock clevis on the power column and the Logo Decal 48" above the base plate on the idler column.
Fig 12.

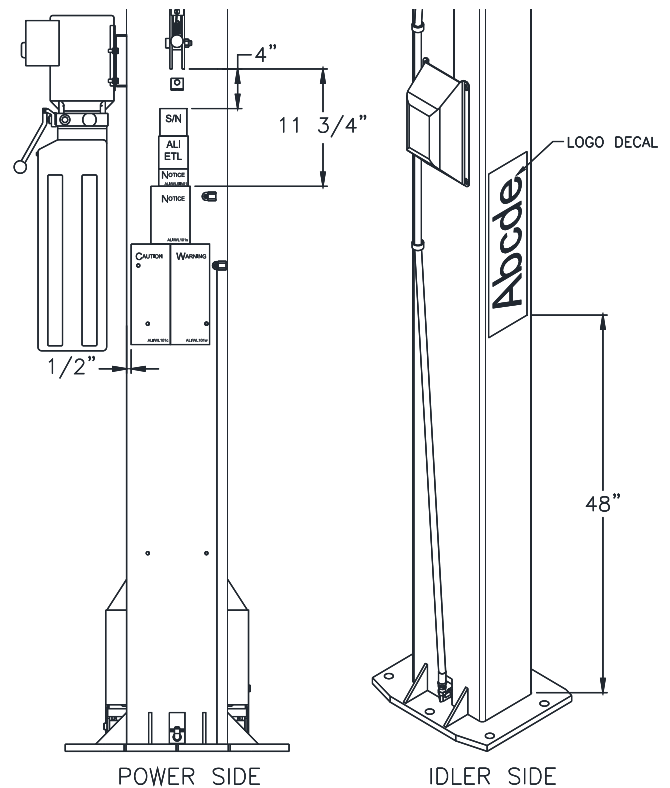

Fig. 12 – Safety & Logo Decal Placement

FINAL ADJUSTMENTS HYDRAULICS

- 48) Lower the lift to the floor and raise the lift approximately one foot.
49) Start with Idler side first. Slowly and carefully loosen the bleed plug on top side of the cylinder just enough to allow the entrapped air to escape. Repeat for power side.
50) Raise lift 6 inches. Repeat previous step until no air comes out of the cylinders.
51) Pressure test hydraulic system. Energize power unit, raise lift to full rise and continue to run motor for additional 10 seconds. (NOTE: pressure relief will make a high pitch squeal sound for these 10 seconds.) Check hydraulic system for leaks.
52) Energize power unit again for 10 seconds. With a clean rag, wipe down both cylinder rods. (The cylinders are shipped with a small amount of clear anti-corrosive lubricant that will be forced out through the wiper when the lift reaches full rise.) **If lubricant is not wiped clean from the cylinder rod, the cylinder will appear to be leaking.**

SYNCHRONIZING CABLES

- 53) Raise lift and ensure carriages lower into same lock position.
- 54) Adjust synchronizing cables so the tension is equal in both cables and carriages are firmly sitting on locks.
- 55) Cycle lift to ensure that locks operate simultaneously.

LOCK RELEASE CABLE

- 56) Raise lift to a lock position but don't set into the lock. Pull and release Power Column lock release handle while watching Idler Column lock. **IMPORTANT: IF IDLER SIDE LOCK PAWL DOES NOT FULLY DISENGAGE, DAMAGE MAY RESULT TO IDLER SIDE CARRIAGE AND OR CABLE SYNCHRONIZING SYSTEM.** Adjust cable tension by adjusting location of threaded cable lug on the mounting tabs. Cable clamps may need to be loosened.
- 57) After both locks fully disengage when the Power Column lock release handle is pulled down, tighten all clamps to secure lock release cable assembly.
- 58) Install both plastic lock covers ensuring lock cable assembly is routed through formed guides in the covers. Replace lock release knob. Ensure lock release handle still disengages both locks with the lock covers in place.

FINAL CHECKOUT PROCEDURE

- 59) Demonstrate the operation of the lift to the owner/operator/employer using a typical vehicle and review correct and safe lifting procedures using the **Lifting It Right** booklet as a guide.
- 60) Return all provided literature (including this manual) to the literature pack envelope and deliver the envelope to the owner/operator/employer.
- 61) Complete the online warranty registration (refer to the included warranty statement).

Wiring Diagram

* EACH LIFT SHOULD HAVE A DEDICATED CIRCUIT WITH A DOUBLE POLE (THREE POLE FOR 3 PHASE) BREAKER OR TIME DELAY FUSE SIZED ACCORDING TO THE FOLLOWING CHART.

	1 ϕ 208-240V	3 ϕ 208V	3 ϕ 220-240V	3 ϕ 440-480V
2Hp	30amp	15amp	15amp	5amp

* WIRING MUST COMPLY WITH ALL LOCAL ELECTRICAL CODES.

* ELECTRICAL CODE REQUIRES A SERVICE DISCONNECT FOR THIS DEVICE. WE SUGGEST THIS SERVICE DISCONNECT BE LOCATED NEAR THE POINT OF OPERATION.

FOR SINGLE PHASE

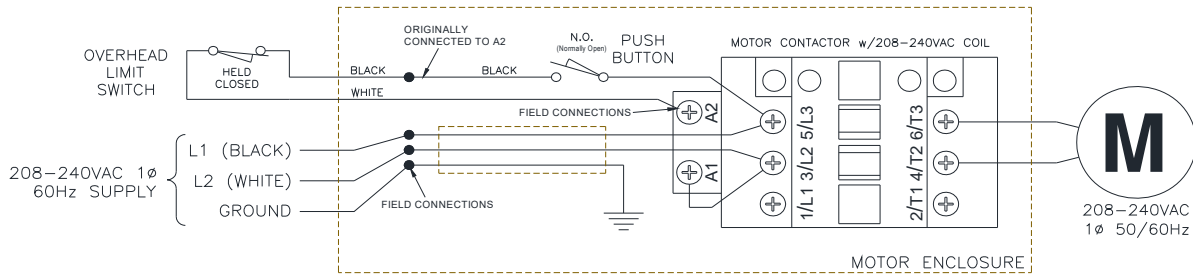

FOR THREE PHASE

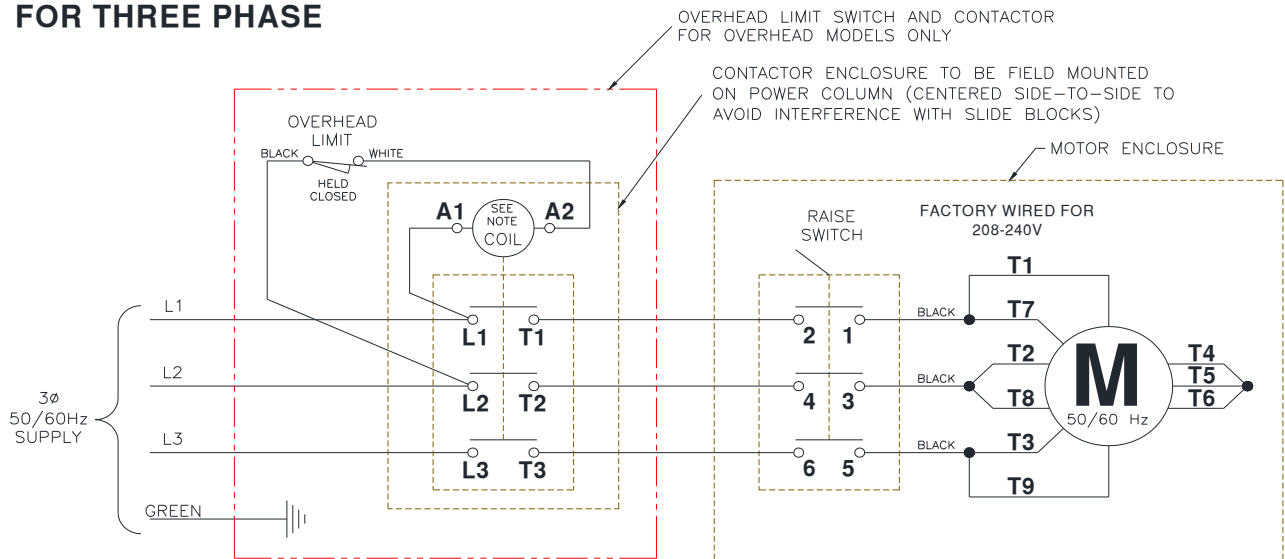

NOTES:

- 1) MOTOR IS FACTORY WIRED FOR 208V OR 220-240V SUPPLY
- 2) MOTOR CONNECTIONS MUST BE RECONFIGURED PER THIS DIAGRAM FOR 440-480V SUPPLY
- 3) CONTACTOR COIL RATING MUST MATCH SUPPLY VOLTAGE (208V, 220-240V, OR 440-480V)
- 4) CONTACTOR MUST BE FIELD MOUNTED ON POWER COLUMN (CENTERED SIDE-TO-SIDE TO AVOID INTERFERENCE WITH SLIDE BLOCKS)
- 5) MOTOR ROTATION IS COUNTER CLOCKWISE FROM TOP OF MOTOR

Fig. 13 – Electrical Wiring Diagram

OPERATION PROCEDURE

SAFETY NOTICES AND DECALS

This product is furnished with graphic safety warning labels, which are reproduced on page 3 of these instructions. Do not remove or deface these warning labels or allow them to be removed or defaced. For your safety, and the safety of others, read and understand all of the safety notices and decals included.

OWNER/EMPLOYER RESPONSIBILITIES

This lift has been designed and constructed according to ANSI/ALI ALCTV standard. The standard applies to lift manufacturers, as well as to owners and employers. The owner/employer's responsibilities as prescribed by ANSI/ALI ALOIM, are summarized below. For exact wording refer to the actual standard provided with this manual in the literature pack.

The Owner/Employer shall ensure that lift operators are qualified and that they are trained in the safe use and operation of the lift using the manufacturer's operating instructions; ALI/SM, *ALI Lifting it Right safety manual*; ALI/ST, *ALI Safety Tips card*; ANSI/ALI ALOIM, *American National Standard for Automotive Lifts-Safety Requirements for Operation, Inspection and Maintenance*; ALI/WL Series, *ALI Uniform Warning Label Decals/Placards*; and in case of frame engaging lifts, ALI/LP-GUIDE, *Vehicle Lifting Points/Quick Reference Guide for Frame Engaging Lifts*.

The Owner/Employer shall establish procedures to periodically inspect the lift in accordance with the lift manufacturer's instructions or ANSI/ALI ALOIM, *American National Standard for Automotive Lifts-Safety Requirements for Operation, Inspection and Maintenance*; and the employer shall ensure that the lift inspectors are qualified and that they are adequately trained in the inspection of the lift.

The Owner/Employer shall establish procedures to periodically maintain the lift in accordance with the lift manufacturer's instructions or ANSI/ALI ALOIM, *American National Standard for Automotive Lifts-Safety Requirements for Operation, Inspection and Maintenance*; and the employer shall ensure that the lift maintenance personnel are qualified and that they are adequately trained in the maintenance of the lift.

The Owner/Employer shall maintain the periodic inspection and maintenance records recommended by the manufacturer or ANSI/ALI ALOIM, *American National Standard for Automotive Lifts-Safety Requirements for Operation, Inspection and Maintenance*.

The Owner/Employer shall display the lift manufacturer's operating instructions; ALI/SM, *ALI Lifting it Right safety manual*; ALI/ST, *ALI Safety Tips card*; ANSI/ALI ALOIM, *American National Standard for Automotive Lifts-Safety Requirements for Operation, Inspection and*

Maintenance; and in the case of frame engaging lift, ALI/LP-GUIDE, *Vehicle Lifting Points/Quick Reference Guide for Frame Engaging Lifts*; in a conspicuous location in the lift area convenient to the operator.

IMPORTANT SAFETY INSTRUCTIONS

When using your garage equipment, basic safety precautions should always be followed, including the following:

1. Read all instructions.
2. Care must be taken as burns can occur from touching hot parts.
3. To reduce the risk of fire, do not operate equipment in the vicinity of open containers of flammable liquids (gasoline).
4. Keep hair, loose clothing, fingers, and all parts of body away from moving parts.
5. Use only as described in this manual. Use only manufacturer's recommended attachments.
6. ALWAYS WEAR SAFETY GLASSES. Everyday eyeglasses only have impact resistant lenses; they are not safety glasses.

SAVE THESE INSTRUCTIONS

LIFTING A VEHICLE

- 1) Ensure that the lifting arms are parked, out to full drive through position.
- 2) Center the vehicle between the columns in the service bay and position the vehicle's center of gravity midpoint between the columns. NOTE: the center of gravity is based on the weight distribution and is not the same as the center point of the vehicle.

DO NOT EXCEED 2500 POUNDS PER ARM.

DO NOT ATTEMPT TO LIFT THE VEHICLE WITH ONLY TWO ARMS, AS THIS WILL VOID THE WARRANTY

ENSURE THAT THE HIGHEST POINT ON THE VEHICLE WILL CONTACT THE OVERHEAD LIMIT SWITCH BAR.

DO NOT PLACE THE VEHICLE IN THE SERVICE BAY BACKWARDS.

REFER TO THE VEHICLE MANUFACTURERS SERVICE MANUAL, TECHNICAL BULLETINS, "VEHICLE LIFTING POINTS GUIDE" (ALI/LP-GUIDE) OR OTHER PUBLICATIONS TO LOCATE THE RECOMMENDED LIFTING POINTS.

- 3) Position the arms and adapters so all four pads contact the vehicle simultaneously.

The vehicle should remain level during lifting.

- 4) Raise the lift until all four wheels are off the ground. Test the stability of the vehicle by attempting to rock the vehicle. Check adapters for secure contact with vehicle lift points. If the vehicle seems unstable, lower the lift and readjust the arms. If the vehicle is stable, raise the vehicle to a height a few inches above the desired working height.
- 5) Lower the vehicle until the locks on both columns engage. The vehicle should remain level when both locks are engaged. If one side engages and the other continues to descend, stop lowering the vehicle, raise it several inches, and try again to engage both locks.

Always lower lift into locks before entering the area beneath the vehicle.

Always use safety stands when removing or installing heavy components.

LOWERING A VEHICLE

- 1) Ensure that the area under the vehicle is clear of personnel and tools.
- 2) Raise the vehicle until both locks are free.
- 3) Disengage the locks by pulling down and holding the lock release lever.
- 4) Lower the vehicle by depressing the lowering valve handle.
- 5) Continue to lower the vehicle until the carriages stop against the base plate. Retract the extension arms and park them.

LOSS OF POWER

If for any reason the lift will not raise off the locks or the locks will not retract, consult factory authorized personnel.

DO NOT OVERRIDE ANY SAFETY FEATURE IN AN ATTEMPT TO LOWER THE LIFT.

MAINTENANCE

To avoid personal injury, permit only qualified personnel to perform maintenance on this equipment. Maintenance personnel should follow lockout/tagout instructions per ANSI Z244.1.

The following maintenance points are suggested as the basis of a routine maintenance program. The actual maintenance program should be tailored to the installation and include a record of each planned maintenance activity and repair maintenance activity performed. Refer to the maintenance section of the ANSI/ALI ALOIM booklet (blue book) provided with the lift.

- If lift stops short of full rise or chatters, check fluid level and bleed both cylinders per Installation Instructions.
- Replace all Safety, Warning or Caution Labels if missing or damaged (**See *Installation instructions page 3.***)

Daily

- Keep lift components clean.
- Check for loose or broken parts.
- Check hydraulic system for fluid leaks.
- Check adapters for damage or excessive wear. Replace as required with genuine Challenger Lifts parts.
- Check lock release activation. When properly adjusted, the idler column lock should rest firmly against the back of the column when engaged and pull clear of the column back when disengaged.

Weekly

- Check synchronizer cables and sheaves for wear. Replace as required with genuine Challenger Lifts parts.
- Check synchronizer cable tension per Installation Instructions. Adjust if necessary. If both threaded ends of either cable have run out of adjustment, then replace both cables. (Cables should always be replaced in sets.)

Monthly

- Torque concrete anchor bolts to 80 ft-lbs.
- Check overhead shutoff switch. While raising lift, operate overhead shutoff bar. Power Unit motor should stop when bar is raised.
- Lubricate carriage slide tracks with heavy viscous grease. (Grease all (4) corners of both columns.)
- Visually inspect concrete floor for cracks and/or spalls within 12" of base plate

If any problems are encountered, contact your local service representative.

Parts Breakdown

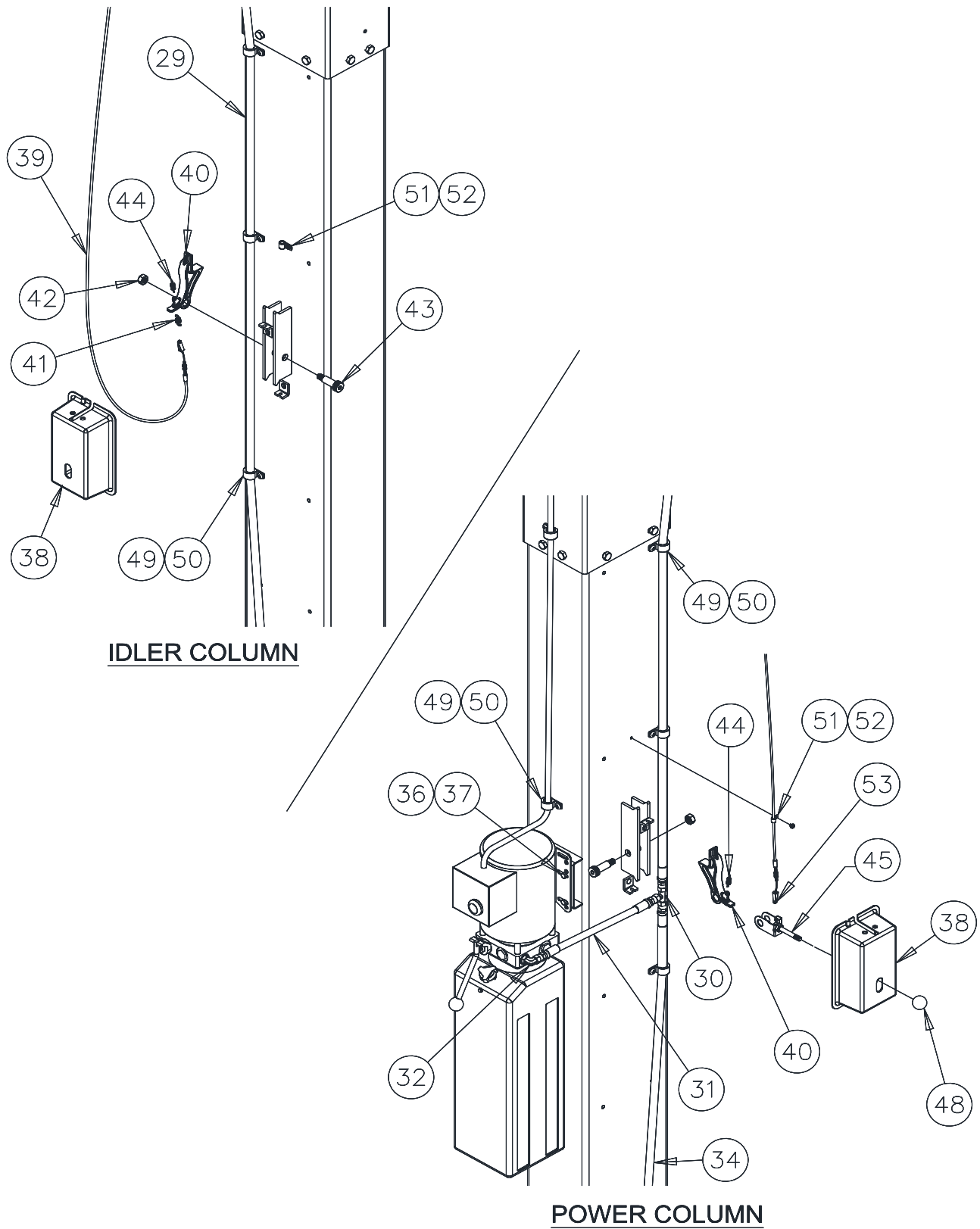

Model EQ10
Installation, Operation and Maintenance

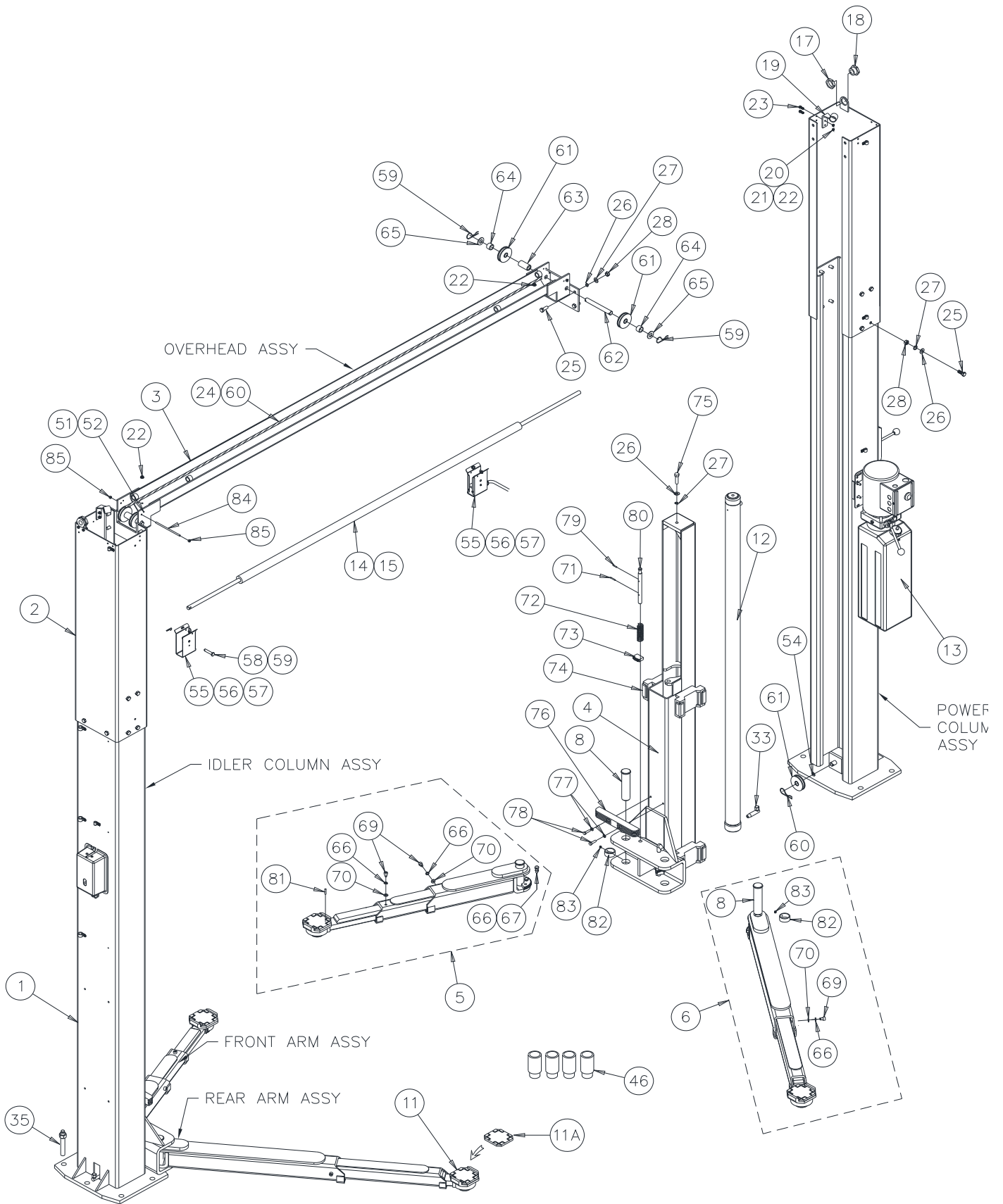

Model EQ10
Installation, Operation and Maintenance

Item #	Part #	Qty	Description	Item #	Part #	Qty.	Description
1	JSJ5-02-01-00V	1	Power Column Weld	39	L5-06-00CH	1	Lock Release Cable
	JSJ5-02-01-00FV	1	Idler Column Weld	40	B1140	2	Lock Pawl
2	JSJ5-02-02-00V	2	Power Column Extension	41	A1132	1	Lock Spring, 1/2" O.D.
	JSJ5-02-02-00FV		Idler Column Extension				
3	JSJ5-03-01-00V	1	Overhead Weld	42	37013	2	M12 Lock Nut
4	JSJ5-08-00CHA	2	Carriage	43	30020	2	Shoulder Bolt
5	JSJ5-10-00EQ	2	Front 3-Stage Arm Assy.	44	A1131	2	Lock Spring, 3/8" O.D.
6	JSJ5-09-00EQ	2	Rear 2-Stage Arm Assy.	45	JSJ5020400CH	1	Lock Release Handle Assy.
				46	B2206-3	4	Pad Adaptor 3"
8	JSJ5-11	4	Arm Pin				
				48	JSJ3-01-02-2-9	1	Lock Knob
				49	1-04982A	9	Clamp, 20mm Dia.
11	B2271	4	Foot Pad Assembly	50	VS10-10-25	9	M8 x 12 Screw
11A	A1104-H	4	Rubber Insert	51	1-05082A	6	Clamp, 5mm Dia.
				52	VS10-10-25	6	M8 x 12 Phillips Pan Head Screw
				53	37119PR	1	Clevis Pin Kit
				54	X10-099	4	Washer 20mm
				55	B2064-V	1	Limit Switch Package (incl. 56-59)
				56	B2065-3	4	M6 x 14mm Screw
12	CLJSJ5-07-00CHA	2	Cylinder, O-Ring	57	B2065-4	4	M6 Serrated Flange Hex Nut
13	AB-9367-DLH	1	Power Unit	58	B2065-5	1	M10 x 55 Clevis Pin
	AD-9367	1	Power Unit, 3Phase	59	GJY12-3	7	Hairpin Cotter Pin
14	JSJ5-03-02CH	1	Shutoff Bar	60	X10-095	8	Nut M16
15	JSJ5-03-03	1	Shutoff Bar Cushion	61	JSJ3-03-02	6	Synch. Sheave
				62	JSJ4-03-03	2	Axle
17	JSJ4-02-17	2	Hose Guide	63	JSJ4-03-05	2	Middle Spacer Sleeve
18	JSJ4-02-18	2	Hose Guide Nut	64	JSJ4-03-06	4	Spacer Sleeve
19	CLJSJ5-02-03-00Q	1	Power Side Hose Guide	65	X10-055	4	Washer
19	CLJSJ5-02-03-00FQ	1	Idler Side Hose Guide	66	X10-074	18	Spring Washer 10mm
20	X10-032	4	Washer 6mm	67	X10-077	12	Screw M10 x 25
21	X10-033	4	Spring Washer 6mm	68	JSJ5-09-07	4	Inner Gear
22	X10-034	12	Nut M6	69	JSJ4-09-08	6	M10 Screw
23	X10-051	4	Bolt M6 x 20	70	X10-073	6	Flat Washer 10mm
24	L5-04-00CH	2	Sync. Cable	71	X10-081	4	Spring Pin 4 x 30
25	X10-037	28	Bolt M12 x 30	72	JSJ4-14	4	Arm Restraint Spring
26	X10-039	30	Spring Washer 12mm	73	JSJ4-12	4	Outer Gear
27	X10-038	30	Washer 12mm	74	JSJ5-08-15	16	Slide Block
28	X10-040	28	Nut M12	75	X10-092	2	Bolt M12 x 45
29	JSJ5-18CH	1	Idler Column Hose	76	JSJ4-05CH	2	Door Guard
30	JSJ4-15	1	Union Tee	77	X10-087	4	Washer 8mm
31	JSJ5-17CH	1	Power Unit Hose	78	X10-088	4	Bolt M8 x 30
32	JSJ5-19	1	O-Ring Elbow	79	X10-080	4	Spring Pin 4 x 24
33	JSJ6-19	2	Cylinder Elbow, O-Ring	80	JSJ5-13	4	Arm Restraint Pin
34	JSJ4-16	1	Power Column Hose	81	B2211	4	Roll Pin, 6 Dia. x 30
35	31058	10	3/4"x5- 1/2" Concrete Anchor	82	JSJ5-22CH	4	40.5 x 48 x 20 Lg. Collar
36	X10-060	4	Bolt M8 x 25	83	JSJ5-23CH	4	M8 x 8 Set Screw Cup Point
37	X10-048	4	Nut M8	84	JSJ5-03-07CH	2	Cable Trapping Rod
38	JSJ5-02-14CH	2	Lock Cover	85	B31061	4	M6 Lock Nut

IMPORTANT

Replace all worn, damaged, or broken parts with parts approved by **Challenger Lifts, Inc.** or with parts meeting **Challenger Lifts Inc.** specifications. Contact your local Challenger Lifts parts distributor for pricing and availability. Call Challenger Lifts at **(502) 625-0700** for the distributor in your area.

REVISIONS

- 2020/11/30 – ADDED STEP TO CHECK THE ARM STOP BOLTS TO MAKE SURE THEY ARE TIGHT. UPDATED LOCK RELEASE CABLE PART NUMBER.
- 2021/09/23 – UPDATED
- 2023/11/15 – UPDATED ANSI/ALI REFERENCE MATERIAL. UPDATED ANCHORING INSTRUCTIONS Pg. 5.
- 2024/03/18 – ADDED ANSI STANDARDS REFERENCE STATEMENT SECTION. PG. 4
- 2024/09/30 – UPDATED ANSI/ALI STATEMENT.
- 2025/06/26 – UPDATED PART NUMBER AND DESCRIPTIONS.
- 2025/11/20 – UPDATED GENERAL SPECIFICATIONS LABELS.
- 2026/06/24 - UPDATED GENERAL SPECS TO INCLUDE 3PH POWER UNIT.